

Hay Rack with Ends (76021908 or 22121818)

**Hardware Kit
22900098**

THANK YOU FOR PURCHASING THIS PRODUCT

Behlen Country has been in the business of providing quality products for more than 75 years. Our products will provide many years of service when maintained by the owner and used in accordance with the capabilities of the product. For questions about this product, or for parts inquiries, please contact our Customer Service Center listed below.

**Hay Rack Attachment
For Feed Bunk**

1. Connect the two End Weldments (2) to the Rack Weldment (1) with four 5/16" x 3/4" Bolts (5) and four 5/16" Flange Nuts (6) as shown.
2. Fasten the bottom of the rack loosely to the End Weldment with one 5/16" x 2 1/2" Hex Bolt (4) and one 5/16" Flange Nut (6) at each end.
3. Flip the bunk upside down and drill four - 11/32" Dia. Holes (two on each end of the bunk) in the poly liner using the holes in the angle end on bunk as the drill guide.
4. Flip the bunk right side up. Attach the bottom of each End Weldment to the bunk using the holes drilled in Step 3 with (5) four 5/16" x 3/4" Bolts and (6) four 5/16" Flange Nuts.
5. Tighten all bolts. **NOTE: Do not over tighten bolts (4) through tube.**

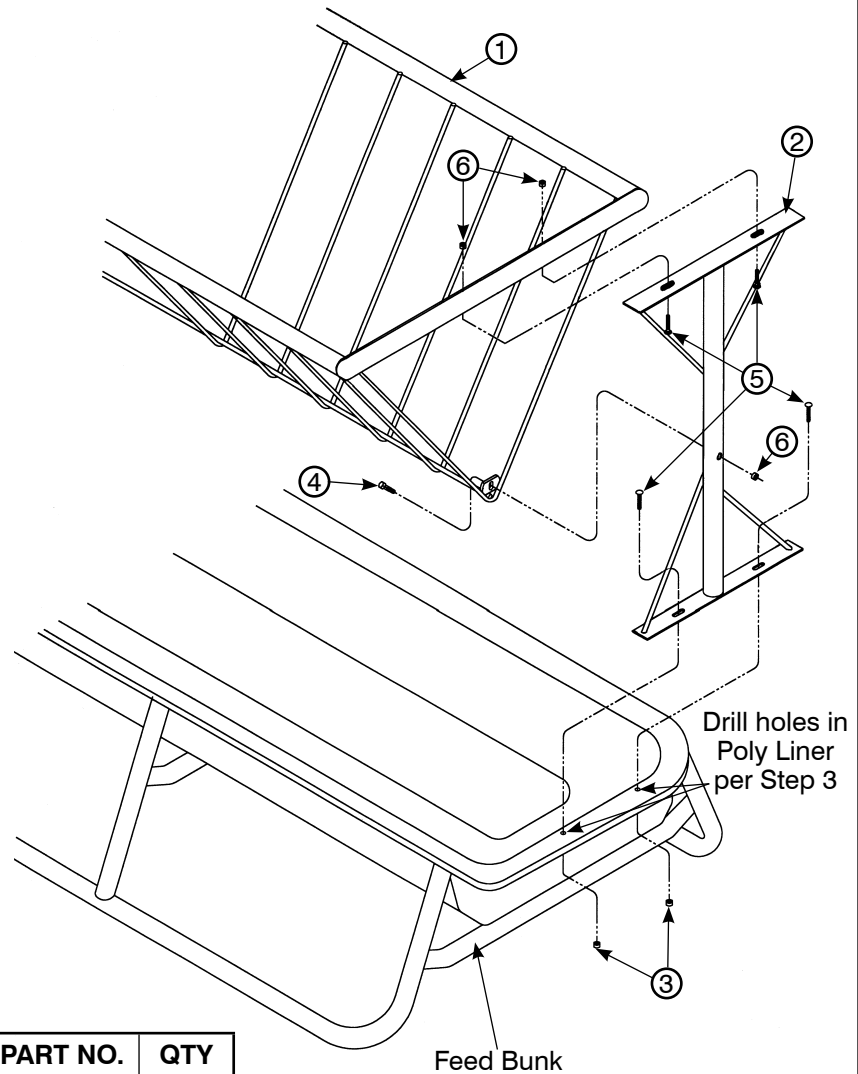

No.	DESCRIPTION	PART NO.	QTY
1	Rack Weldment	----	1
2	V-Hay Rack End Weldment	22400138	2
4	*Bolt, Hex 5/16" - 18 x 2 1/2" z.p.	----	2
5	*5/16" - 18 x 3/4" Bolt z.p.	----	8
6	*Nut, 5/16"- 18 Flange z.p.	----	10

**Standard Hardware Items. May be purchased locally.*



CUSTOMER SERVICE CENTER

PO Box 569
Columbus, NE
68602-0569

Ph: 800-447-2751
Fax: (402) 563-7447
www.behlencountry.com