

Poly Lick Tank PLT-285

Hardware Kit 28900158

For questions about this product, or for parts inquiries, please contact our Customer Service Center listed below.

This hardware kit contains the following:

DESCRIPTION	PART NO.	QTY.
5/16" - 18x1" Hex Bolt S.S.	3188254	4
5/16" - 18x1" Hex Nut S.S.	2688218	4
5/16" - Std. Washer S.S.	3948138	8

These hardware kits are attached to the lid assembly and lick wheel assemblies. Three hardware kits are required to assemble one complete lick tank with two lick wheels. Assembly instructions are listed below.

1. Install bracket (1) and wheel (2) using four 5/16" x 1" hex bolts (5), four 5/16" hex nuts (7), and eight 5/16" washers (6).
2. Repeat step 1 for each additional wheel used.
3. Place lid (4) on top of tank (3). Use four holes around top edge of lid as a guide and drill through lip of tank. Fasten with four 5/16" x 1" hex bolts (5), eight 5/16" washers (6) and four 5/16" hex nuts (7).

NOTE: Be sure that none of the wheels are positioned directly over any reinforcing pockets in the tank base before drilling holes.

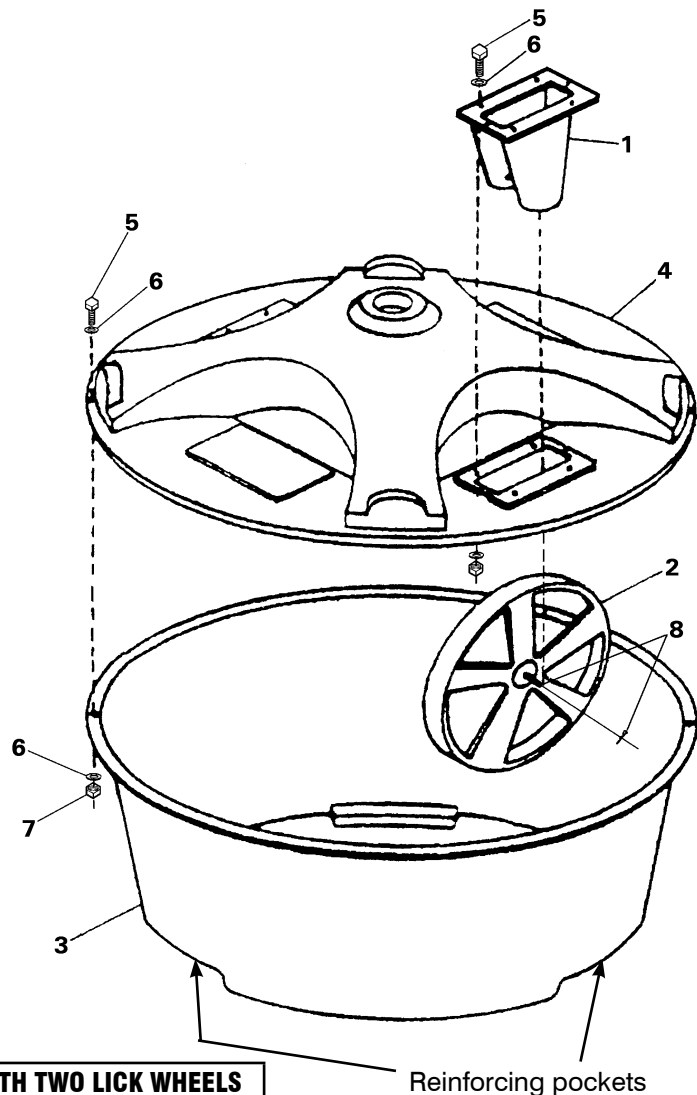

PARTS LISTING FOR ONE COMPLETE LICK TANK WITH TWO LICK WHEELS			
ITEM	DESCRIPTION	PART NO.	QTY.
1	Lick Wheel Bracket	1368072	2
2	Lick Wheel	3988021	2
3	Poly Lick Tank Base	28110236	1
4	Poly Lick Tank Lid Assembly	28110224	1
5	*5/16" - 18 x 1" Hex Bolt s.s.	3188254	12
6	*5/16" Std. Washer s.s.	3948138	24
7	*5/16" - 18 Hex Nut s.s.	2688218	12
8	Axle & Cotter Pin Combo	2868062	2

*Standard Hardware Items. May be purchased locally.

Behlen[®] COUNTRY

CUSTOMER SERVICE CENTER

PO Box 569
Columbus, NE
68602-0569

Ph: 800-447-2751
Fax: (402) 563-7447
www.behlencountry.com