

End Cap Marketing Display (Assembly Instructions)

Hardware Package
80900010

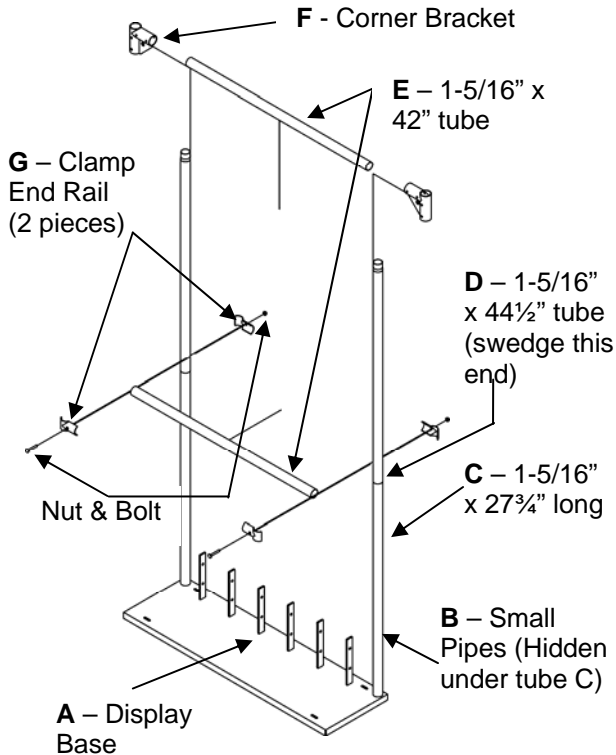

Step 1: Set the display base (A) upright as shown in the diagram.

Step 2: Slide small pipes (B – Not shown as they are in place on the diagram) over the pegs on the display base in area shown.

Step 3: Slide 27 $\frac{3}{4}$ " long tube (C) over pipe (B) at both ends of the display base.

Step 4: Slide the swedge end of tube 44 $\frac{1}{2}$ " long (D) into each tube (C).

Step 5: Insert a corner bracket (F) into the end of each 42" long tube (E).

Step 6: Slide the bracket and tube assembly just made over each end of vertical tube (D). The top is now assembled.

Step 7: Affix one Clamp End Rail (G) onto the vertical frame just created. Use the nut and bolt provided as listed on the drawing. Be sure to leave this loose.

Step 8: Slide in 42" long tube (E) into the clamp end rail (G) just attached.

Step 9: Take the other clamp end rail (G) and the nut and bolt provided. Attach it to the other side with 42" long tube (E) in place.

Step 10: The frame dimension for the top should be roughly 36" x 46". Tighten each nut and bolt on the clamp end rail (G) to those dimensions listed.

Material list for above assembly

<u>Letter Code</u>	<u>Description</u>	<u>Qty</u>
A	Display Base (Complete with required hardware)	1
B	Small Pipes	2
C	1-5/16" x 27 $\frac{3}{4}$ " Long Tube	2
D	1-5/16" x 44 $\frac{1}{2}$ " Long Tube – Swedge One End	2
E	1-5/16" x 42" Long Tube	2
F	Corner Bracket	2
G	Clamp End Rail (Pair)	2
*	5/16" x 1 $\frac{3}{4}$ " Bolt with Nut	2 ea.

Behlen COUNTRY™

Affixing the gate samples on the display base -

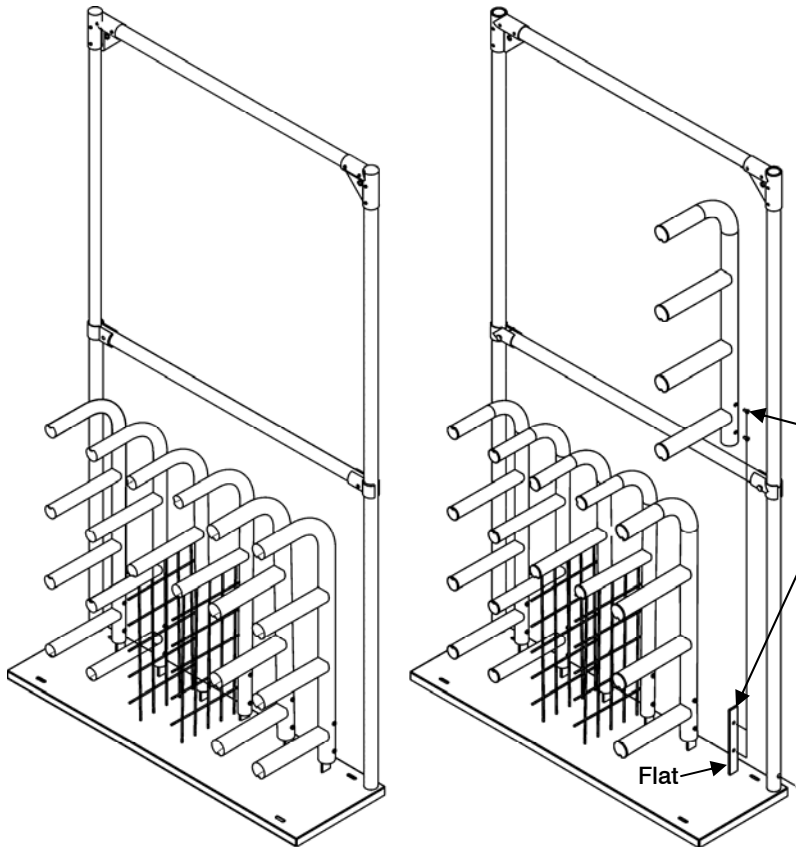

To affix each gate sample to the base, use the bolts provided in the upright flat attached to the base.

- A. Remove the two bolts on each flat.
- B. Slide the gate sample over the flat.
- C. Line up the holes in the sample with the holes in the flat.
- D. Fasten the gate samples using the bolts which will screw directly into the weld nuts on the flats.
- E. Tighten bolts to ensure gate sample is snug.

Repeat these steps until all samples are attached.

Attach the signage using the zip ties provided. See the photo below for reference on how to attach.

Note: It is best to attach the gate samples in order of strength. The heaviest samples should be on the left-hand side when facing the display. Proceed, placing the lighter gauge samples to the right. See the photo below of a complete display.

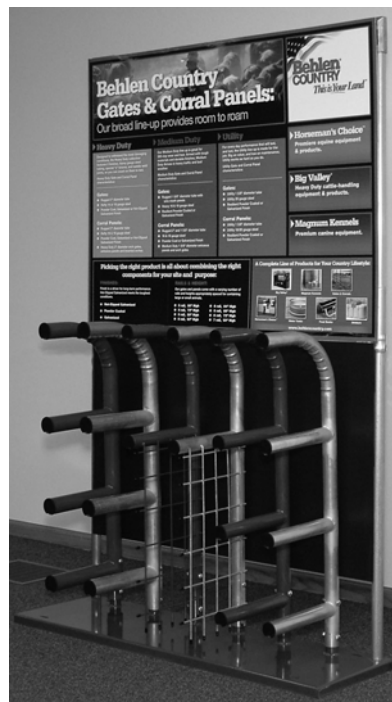

If you have questions about assembly or parts, please call Behlen Country at 800-447-2751.