

Rotary Tillers

Congratulations on your purchase of an authentic ABI 3-point attachment! Please read these instructions thoroughly and contact customer service if further instruction for safe and effective use is needed.

TO THE CUSTOMER

This manual contains valuable information about your new Rotary Tiller. It has been prepared to give you helpful suggestions for safety, operation, adjustment and service.

It is the owner's and or operator's responsibility to:

- Read and understand the information contained in this manual. The use of this equipment is susceptible to certain hazards that cannot be protected against by mechanical means or product design. All operators of

this equipment must read and understand this entire manual, paying particular attention to safety and operating instructions, prior to using.

- Operate, lubricate, assemble, and maintain the equipment in accordance with all instructions and safety procedures in this manual.
- Inspect the equipment prior to each use and replace or repair any parts that are worn or damaged.

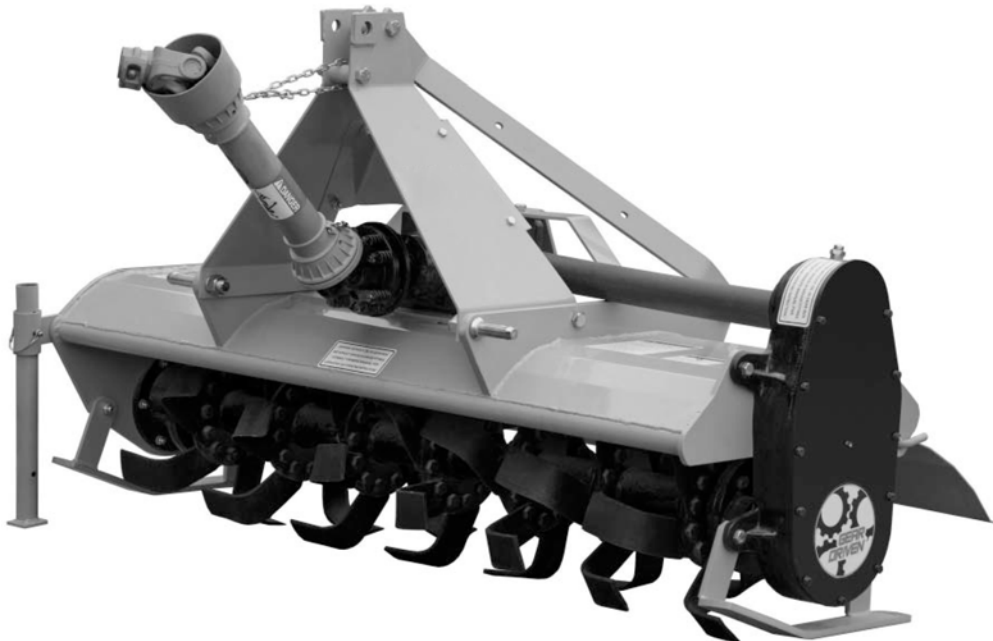

STATEMENT OF POLICY

It is the policy of ABI Attachments to improve its products where it is possible and practical to do so. ABI Attachments reserves the right to make changes or improvements in design and construction at any time, without incurring the obligation to make these changes on previously manufactured units.

CUSTOMER SERVICE CENTER

Ph: (855) 211-0598 M-Th 8^{AM} - 8^{PM}; Fri. 8-5 EST
ABIsupport.com

ASSEMBLY, OPERATION, & MAINTENANCE INSTRUCTIONS

Tools Needed: Socket & wrench sizes - 9/16", 3/4", 15/16" and 1 1/4". An impact wrench is preferred.

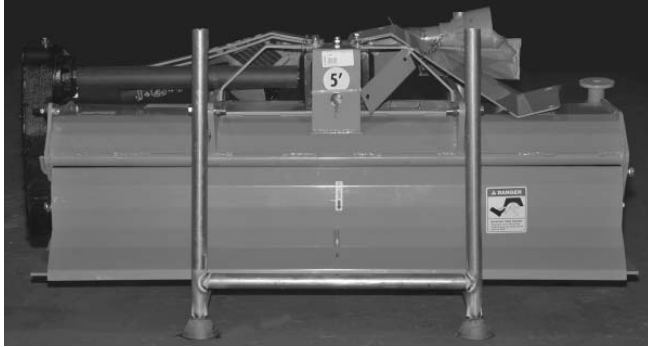

1. With Rotary Tiller still in shipping rack, set on level ground.

2. Insert a lift strap through the gearbox mounting frame as shown at right.



3. Remove PTO shaft from Tiller as shown below.

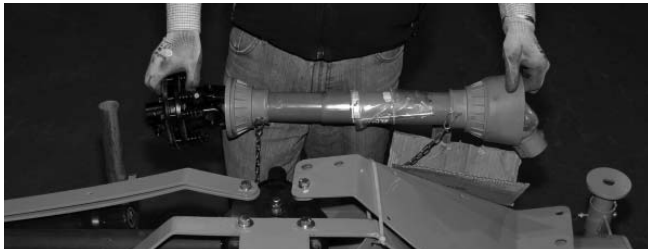

4. Remove the two bolts which hold the Tiller to the Shipping Rack.



5. Using an adequately sized machine, lift the Tiller from the Shipping Rack.



6. Before setting on level ground, remove pin from kickstand (right) and adjust so that the Tiller is stable as shown below.



7. Remove lift strap.



8. Remove the Hardware Package and the PTO Shield from the assembly. Detach the two "A" Arm Plates and Rear Braces with a 3/4" wrench and discard bolts.



9. Attach "A" Arm Plates to the front of the Tiller deck using the Category 1 pins, washers, nuts, and 5/8" x 2" hex bolts, nuts, and washers.



NOTE: Hand tighten all bolts.

10. Attach the **rounded end** (one end is flatter than the other) of the Rear Braces to the outside of the rear Tiller deck braces using the 5/8" x 2" hex bolts, washers and nuts provided.



ASSEMBLY, OPERATION, & MAINTENANCE INSTRUCTIONS

10. Attach the other end (the one with the flatter end) of the Rear Braces to the inside of the "A" Arm Plates using the 5/8" x 4" hex bolt, washers, nuts, and 1 1/2" spacer provided.



11. Using the 5/8" x 4" hex bolt, washer, nut and spacer, connect the two "A" Arm Plates as shown using the 2 1/4" Spacer.

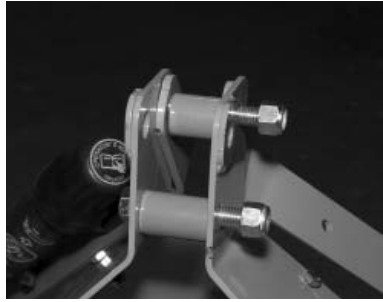

12. Attach the PTO Shield to the inside of the "A" Arm Plates as shown using the 1/4" x 3/4" bolts and nuts provided.

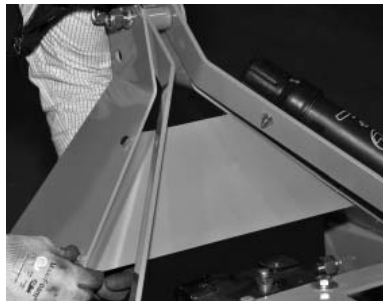

13. Attach the Rear Guard Chain Assembly to the Rear Guard as shown.



14. Tighten all bolts.

SAFETY

READ AND FOLLOW THE INSTRUCTIONS IN THIS MANUAL, ESPECIALLY IN THE SAFETY SECTION. FAILURE TO DO SO COULD RESULT IN SERIOUS INJURY OR DEATH.



**THIS SYMBOL MEANS
ATTENTION! BE ON THE ALERT!
YOUR SAFETY IS INVOLVED!**

TAKE NOTE! THIS SAFETY ALERT SYMBOL IS FOUND THROUGHOUT THIS MANUAL. THIS SYMBOL IS USED TO CALL YOUR ATTENTION TO INSTRUCTIONS CONCERNING YOUR PERSONAL SAFETY AND THE SAFETY OF OTHERS.

CRITICAL TERMS:

The critical terms DANGER, WARNING and CAUTION are used with the safety messages in this manual and with each safety decal. They are defined as follows:

DANGER

DANGER: Indicates an immediate hazardous situation that, if not avoided, could result in serious injury or death. This Critical Term is to be limited to the most extreme situations, typically for machine components that, for functional purposes, cannot be guarded.

WARNING

WARNING: Indicates a potentially hazardous situation that, if not avoided, could result in serious injury or death, and includes hazards that are exposed when guards are removed. It may also be used to alert against unsafe practices.

CAUTION

CAUTION: Indicates a potentially hazardous situation that, if not avoided, may result in minor or moderate injury. It also may be used to alert against unsafe practices.

Equipment Safety Guidelines

• Safety of the operator and bystanders is one of the main concerns in designing and developing a Rotary Tiller. However, every year accidents occur which could have been avoided by a few moments of thought and a more careful approach to handling equipment. You, the operator, can avoid many

accidents by observing the following precautions and insist those working with or for you adhere to them.

- In order to provide a better view, certain illustrations in this manual may show an assembly with a safety guard removed. However, equipment should never be operated in this condition. Keep all guards in place. If guard removal becomes necessary for repairs, reinstall the guard prior to use.

- Replace any safety decal that is not legible or is missing. The locations of such safety decals are indicated in this manual.

- Never operate this equipment while using alcoholic beverages or drugs that can hinder alertness or coordination. Consult your doctor about operating this machine while taking prescription medications.

- Under no circumstances should children under the age of 18 be allowed to work with or around this equipment. Do not allow anyone to operate or assemble this equipment until they have read this manual and have developed a thorough understanding of the safety precautions and operation. Review safety instructions with all users often.

- This equipment is dangerous to anyone unfamiliar with its operation. The owner/operator is responsible for reading and following all of the instructions in the manual. The operator should be a responsible, properly qualified and physically able person familiar with farm machinery and competent in this equipment's operation.

- Never exceed the limits of a piece of machinery. If its ability to do a job, in a safe manner, is in question - DON'T TRY IT.

- Use a tractor equipped with a Roll Over Protective System (ROPS) and seat belts. Only properly trained people should operate this machine. Always stop the PTO, set break, shut off the tractor engine, remove the tractor key, and allow implement to come to a complete stop before dismounting tractor. Never leave equipment unattended with tractor running.

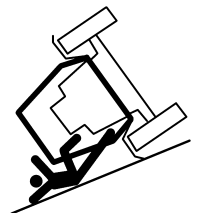

- Do not modify the equipment in any way. Unauthorized modifications could result in serious injury or death and may impair the function and shorten the life of the equipment and void any warranty coverage.

- In addition to the design of this implement, including safety decals and safety equipment, accident prevention is dependent upon the

awareness, common sense, forethought, and proper training of everyone involved in the operation, transport, maintenance, and storage of the machine. Also refer to safety messages and operating instructions in each of the appropriate sections of the tractor manual. Pay close attention to the safety decals affixed to both the tractor and Rotary Tiller.

- For non-agricultural applications, OSHA, ASAE, SAE, and ANSI standard require the use of chain guards, deflectors, or solid skirts at all times. We strongly recommend the use of chain guards or solid skirts to agricultural applications as well to reduce the risk of property damage, serious bodily injury or even death from objects thrown or from contact with the cutting blades.

Starting And Stopping Safety

- Check the tractor master guard over the PTO shaft. Make sure it is in good condition and fastened securely to the tractor. Purchase a new guard if the old guard is damaged or missing.
- All tractors that are not equipped with a “live” Power Take Off (PTO) need to be equipped with an over-running PTO clutch. These are available through most farm equipment stores.

WARNING

- When attempting to stop a tractor that does not have a live PTO, the momentum created by the blades of the tiller can cause the tractor to be pushed forward. Do NOT operate this Tiller unless the tractor has a live or independent PTO.
- NOTE: The addition of an over-running PTO clutch may change the length of the PTO driveline required. Pay extra attention to the instructions on the PTO driveline installation. Be sure that the driveline system guarding is sufficient.
- The Rotary Tiller operating power is supplied from the tractor PTO. Refer to your tractor manual for PTO engagement and disengagement instructions. Know how to stop the tractor and Tiller quickly in case of emergency.
- The engine RPM should always be at idle speed when engaging the PTO. Once engaged and you are ready to start cutting, increase the PTO speed to approximately 540 RPM and maintain throughout the cutting operation. The Rotary Tiller is designed for use on tractors with a 540-RPM power take off. Do not exceed horsepower recommendations.
- Most accidents occur because of neglect or

carelessness. Keep all assistants and bystanders at least 100' from the operating Rotary Tiller.

- The majority of the accidents involve entanglement on the driveline, injury of bystanders by the objects thrown by the rotating tines, and operators being knocked off the tractor by low hanging limbs and then being run over by the tiller. Accidents are most likely to occur with machines that are loaned or rented to someone who has not read the owner's manual and is not familiar with a Rotary Tiller.
- Install and secure all guards and shields before starting or operating. The driveline guards and tractor guards should be used and maintained in good working condition. They should be inspected carefully before each use for missing or broken parts. Worn items must be replaced at once to reduce the possibility of injury.
- Disengage Power Take Off (PTO) and place tractor transmission in neutral before attempting to start the tractor engine.
- Various objects, such as wire, cable, rope, or chains can become entangled in the working parts of the tiller. Clean these out immediately to prevent damage to the tiller. Never allow the tines to contact objects which may cause damage to the tiller or serious injury to the operator. Never assume an area is clear. Always check!
- Always stop the tractor, disengage PTO, allow tines to come to a complete stop, lower implement to the ground, set brake, shut off the tractor engine and remove the ignition key before dismounting tractor. Never leave equipment unattended while the tractor is running.
- Never place hands or feet under tiller. Stay clear of all moving parts.
- Do not reach or place any part of your body under the equipment until it is blocked securely.
- Do not allow riders on the Rotary Tiller or tractor at any time. There is no safe place for riders.



Preparation

- Never operate the tractor and tiller until you have read and completely understand this manual, the Tractor Operator's Manual, and each of the safety messages found on the safety decals on the tractor and tiller.
- Personal protection equipment including hard hat, safety glasses, safety shoes, and gloves are recommended during assembly, installation, operation, adjustment, maintenance, repairing,

ASSEMBLY, OPERATION, & MAINTENANCE INSTRUCTIONS

removal, or moving the implement. Do not wear loose fitting clothing or jewelry and be sure to contain long hair around equipment.

• **PROLONGED EXPOSURE TO LOUD NOISE MAY CAUSE PERMANENT HEARING LOSS!** Tractors with or without tillers attached can often create enough noise to cause permanent hearing loss. We recommend that you use hearing protection if the noise in the operator's position exceeds 80db. Long-term exposure to noise levels over 90db adjacent to the operator may cause permanent total hearing loss. **NOTE:** Hearing loss from loud noises is cumulative over a lifetime, with no chance of natural recovery.

• Always wear your seat belt. Serious injury or even death could result from falling off the tractor - particularly during a rollover when the operator could be trapped under the ROPS or the tractor.

• Operate only in daylight or good artificial light.

• Ensure tiller is properly mounted, adjusted and in good operating condition.

• Ensure that all safety guards and safety decals are properly installed and in good condition.

• Do not operate unless all personnel, livestock, and pets are at least 100' away to prevent injury by thrown objects.

• Never operate tractor and Tiller under trees with low hanging limbs. Operators can be knocked off the tractor and then run over by the tiller.

• The rotating parts of this machine have been designed and tested for rugged use. However, they could fail upon impact with heavy, solid objects such as steel guardrails, concrete abutments, and tree stumps. Such an impact could cause broken objects to be thrown outward at very high velocities. To reduce the possibility of property damage, serious injury, or even death, never allow the tines to come in contact with such objects.

• Stop tiller and tractor immediately upon striking an obstruction. Turn engine off, remove key, then inspect and repair any damage before resuming.

• Stay alert for uneven terrain and holes. Remove all rocks, roots, posts and other hazards. Keep away from drop-offs and hazards that could cause rollover. Use extreme care and maintain minimum ground speed when transporting or operating on hillsides, close to ditches or fences or over rough ground. Be careful and slow down when turning sharp corners and changing direction on slopes. Do not start or stop suddenly on slopes and avoid operating on steep slopes. In extremely uneven terrain, rear wheels weights, front tractor weights, and/or tire ballast should be used to improve stability.

• Drive Rotary Tiller diagonally over sharp dips and avoid sharp drops to prevent tractor and Rotary Tiller from "hanging up". Always travel downward on slopes, never across the face. Check tractor manual for proper use on slopes.

• A minimum of 20% of the tractor and equipment weight must be on the tractor's front wheels. Without this weight, the tractor could tip over, causing personal injury or death. The weight may be attained with a front-end loader, front wheel weights, ballast in the tires or front tractor weights. When attaining a minimum 20% of the tractor and equipment weight on the front wheels, you must not exceed the ROPS weight certification. Weigh the tractor and equipment. Do NOT guess or estimate!

Pre-Operation Instructions

IMPORTANT - Top and side gearboxes are shipped without oil or grease in the fittings. (1 qt. oil for top gearbox and 3 qts. for side gearbox recommended).

• **ALWAYS CHECK OIL IN GEARBOXES WITH UNIT ON LEVEL GROUND BEFORE OPERATING.** Unit has two gearboxes, make sure both are filled to specifications below using type 80W-90 gear oil. **DO NOT OVERFILL OR DAMAGE TO THE GEARBOXES MAY RESULT.**

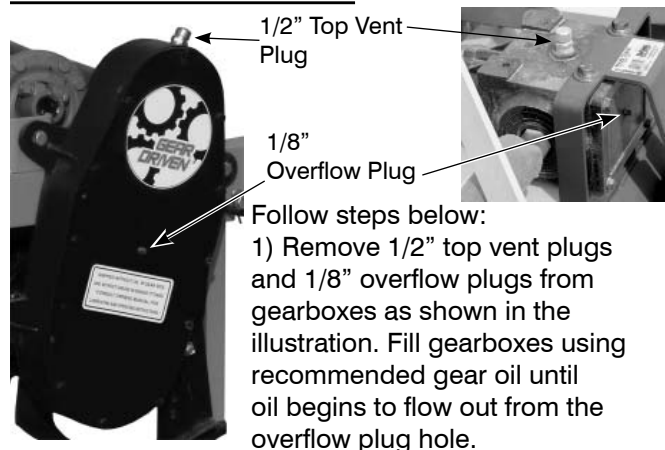

1) Remove 1/2" top vent plugs and 1/8" overflow plugs from gearboxes as shown in the illustration. Fill gearboxes using recommended gear oil until oil begins to flow out from the overflow plug hole.

2) Replace top vent and overflow plugs and wipe away any excess oil. Be sure vent plugs are kept clear of any dirt or debris to allow air to pass through.

3) Grease all zerks using SAE high temp multi-purpose lithium grease.

4) With the Rotary Tiller positioned on level ground, adjust the tractor lift arms so that when lifted, the rotor bar remains parallel to the ground.

5) With the Rotary Tiller attached to the tractor, raise and support the Tiller with secure blocking. Adjust the skids located on the sides of the tiller. The adjustment

bolts for both right and left sides should be positioned in the same adjustment hole. This allows the Tiller to till the same depth on each side.

6) Raise the Tiller and remove the blocking.

Slip Clutch Adjustment

The Slip Clutch is designed to slip so that the gearbox and driveline are protected if the implement strikes an obstruction.

A new slip clutch or one that has been in storage over the winter may seize. Before operating the implement, make sure it will slip by performing the following:

1. Turn off tractor engine and remove key.
2. Remove driveline from tractor PTO.
3. Loosen the cap screws to remove all tension from the spring plate.
4. Hold clutch hub solid and turn shaft to make sure clutch slips.
5. If clutch does not slip freely, disassemble and clean the thrust plate faces, flange yoke, and clutch hub.
6. Reassemble clutch.
7. Finger tighten spring until it is against the thrust plate of the clutch and then tighten each of the nuts by $1\frac{1}{2}$ - 2 full rotations. Try the implement and watch for clutch to slip. Adjust nuts another $\frac{1}{2}$ turn as needed until clutch stops slipping.
8. If clutch continues to slip when the spring is compressed, check friction disc for excessive wear. Disc are $\frac{1}{8}$ " thick when new. Replace discs after $\frac{1}{16}$ " wear. Minimum disc thickness is $\frac{1}{16}$ ".

PTO Shaft Modification

Read and thoroughly understand the following instructions before attempting assembly. If you are not comfortable making the necessary changes, please refer this project to a qualified professional.

NOTE: Due to the many variations in tractor hitch points and distances between equipment gearbox input shaft and tractor PTO output shafts, some combinations will require PTO shafts to be shortened. If it is determined that this is the case, follow the instructions in the following steps.

1. Raise and lower the Tiller in order to locate the shortest distance between gearbox input shaft and tractor PTO output shaft. With the Tiller in the shortest distance position, shut down the tractor and **secure the tiller in place.**

To install PTO shaft with Slip Clutch:

- 1) Remove bolt as shown.
- 2) Attach PTO shaft.
- 3) Line up hole and groove in shaft.
- 4) Reinsert and tighten bolt.

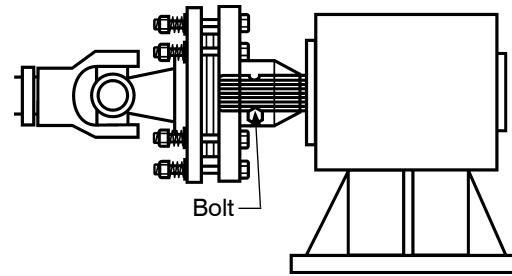

⚠ WARNING ⚠

WARNING: If the Tiller is raised up so that the PTO shaft is at an angle sharper than 35 degrees, PTO MUST BE STOPPED!

2. Pull apart the PTO shaft and attach outer section to tractor PTO shaft. NOTE: Be sure to pull on PTO shaft section to ensure yoke has locked into place.
3. Place and hold inner PTO shaft section next to outer section and check if PTO shaft is too long. Each section should end approximately 3" short of reaching the U-joint shield on the opposite section. If the shaft is too long, measure 3" back from each U-joint shield and mark the other shaft section. Be sure to do this for both PTO shaft halves. **NOTE: Do not cut PTO shaft sections at this time.**
4. As in Step 3, hold PTO shaft sections together and check for a minimum of 6" of overlap. If the PTO shaft has been marked for cutting, the overlap is the distance between the two marks. If the PTO shaft has less than 6" of overlap, **DO NOT USE.**

NOTE: If the PTO shaft is too long, see further instructions below for sizing.

5. Apply multi-purpose grease to the outside of the male (inner) PTO shaft section. Assemble PTO shaft and install on Tiller and tractor.
6. Pull on tractor side of PTO shaft yoke to be sure it has locked in place. Make certain PTO shaft shielding is in place and good working condition.
7. The PTO shaft shield is a non-rotating design and must be secured prior to use. Using the chain on each yoke shield, attach to a fixed object on the tractor and equipment ends so that the PTO shaft shield will not rotate during operation.

Cutting PTO Shaft

1. After determining how much to cut off, be sure to cut off equal lengths of each PTO shaft section, but be careful not to cut off too much. Clamp end of PTO shaft in a vice, and cut off shield where marked. (See Fig. 1).



2. Using the cut section of the shield as a guide, cut the same amount off of each shaft. (See Fig. 2A, 2B & 2C).

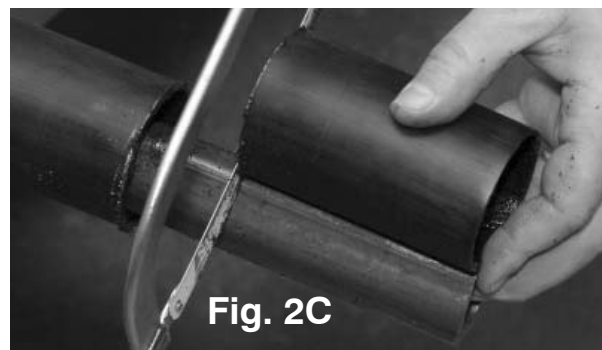
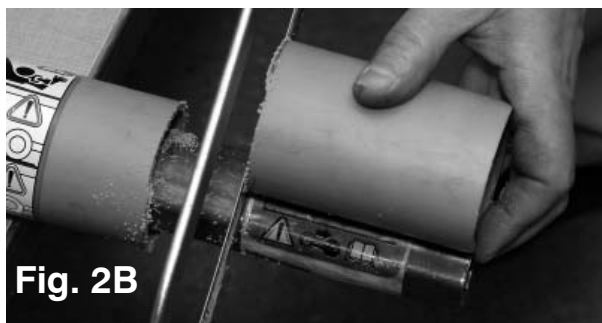

3. Repeat Steps 1 and 2 for the other section of the PTO shaft.
4. Use a file to deburr the PTO shafts. Clean up all chips, burrs and filings from both ends of the PTO shaft.

IMPORTANT NOTE: If the bolt that attaches the PTO shaft to the gearbox gets sheared, replace with a **Grade 2 bolt ONLY**. Replacement with any other grade of bolt will void your warranty and may cause permanent damage to the PTO shaft, gearbox, or tractor.

Attaching To Tractor

⚠ WARNING ⚠

Never stand, or allow anyone else to stand, between the tractor and the Tiller while backing the tractor up to the hitch.

- 1) Attach to the tractor's 3-Point hitch as described in the Tractor's Operator's Manual. Set tractor's lift control stop at a position that will prevent the PTO shaft from coming in contact with the front edge of the Tiller when it is at full lift. Consult your tractor manual for instructions.
- 2) Apply any multi-purpose grease to the outside of the male (inner) PTO shaft section. Assemble PTO shaft and install on Tiller and tractor.

⚠ DANGER ⚠

Failure to install the retaining clip on the gearbox input shaft would allow the driveline to swing freely if the bolt is sheared causing possible injury or death.

- 3) Pull shaft on tractor side of PTO shaft yoke to be sure it has locked in place. Make certain PTO shaft guards are in place and in good working condition.
- 4) The PTO shaft guard is a non-rotating design and must be secured prior to equipment use. Use the chain on each yoke guard to attach to fixed objects on both the tractor and equipment ends that will not allow the PTO shaft guard to rotate during operation.

Operating Instructions

Start the tractor and set at idle RPM. With the Tiller lifted off the ground, engage PTO and slowly advance throttle to 540 RPM. **NOTE: Rotary Tiller is designed to run at 540 RPM ONLY.**

Select a low gear on the tractor and begin to move forward. Tractor ground speed is to be controlled by gear selection **ONLY** and not engine speed. **Travelling at a fast ground speed while using the Tiller could damage the unit.** As the tractor moves forward, slowly lower the Tiller down. Allow the tiller tines to gradually engage the ground.

The Tiller is designed to be operated in a forward direction **ONLY**. Running in reverse could damage the Tiller and the tractor and void the Tiller warranty.

Adjust the back plate with regulating chain until the desired mulching effect is achieved. **NOTE: NEVER ATTEMPT TO ADJUST THE ROTARY TILLER WHILE THE TRACTOR IS RUNNING.**

Do **NOT** allow the tractor to engine or Tiller to bog down or stall. This causes undue wear and tear on the Tiller and the tractor. If this continues to happen, reduce ground speed and raise tilling depth of Tiller. Never attempt to remove objects from the rotary bar until the tractor has been shut down and the Tiller tines have completely stopped.

WARNING

Never attempt to turn the tractor or travel in reverse with the PTO engaged and the Tiller in the ground. Always raise the Tiller out of the ground when backing up or attempting to turn. Failure to do so may cause damage to the Tiller.

Never attempt to operate the Tiller on sudden steep inclines or declines with the PTO engaged. **ALWAYS** raise the Tiller out of the ground when traveling over sudden inclines or declines. Failure to do so may cause damage to the Tiller.

Transport Safety

- Always comply with all state and local laws governing highway safety and movement of farm machinery on public roads.
- The use of flashing amber lights is acceptable in most localities. However, some localities prohibit their use. Local laws should be checked for all lighting and marking requirements. Always use proper lighting and a Slow Moving Vehicle (SMV) sign when on a highway or road. Do **NOT** exceed 20 mph. Reduce speed on rough roads.
- Plan your route to avoid heavy traffic.
- Always yield to oncoming traffic at narrow bridges, intersections, etc. Watch for traffic when operating near or crossing roadways.
- Take hills and curves only at a low speed and at a gradual angle. Make certain that at least 20% of the tractor's weight in the front wheels to maintain safe steering. Slow down on rough or uneven surfaces. Check the tractor's manual for proper use on slopes.
- Use extreme care and maintain minimum ground contact when operating close to ditches or fences. Be careful when turning sharp corners.

Maintenance

- 1) Periodically check and maintain proper gear oil levels in both top and side gearboxes. Check the vent plugs of both gearboxes and make sure they are clean and free of dirt or debris to ensure proper airflow.
- 2) Every 8 hours, grease "out board" hub (below left), PTO shaft universal joints (below right), PTO shaft safety shield, and PTO telescoping surface. **Use ONLY grade Type II tube grease. NOTE: Do NOT grease the slip clutch assembly.**

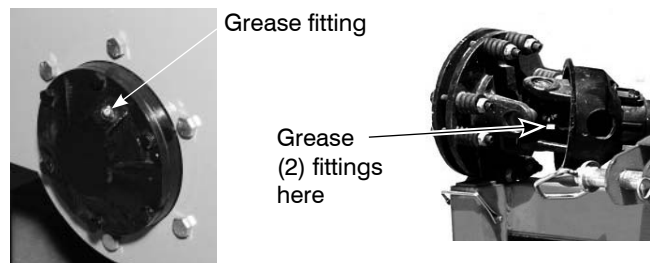

- 3) Before each use, check to make sure all safety shields are installed and working properly.
- 4) After each use clean the debris from the Tiller tines. Inspect for any damaged or worn parts and replace before next use.
- 5) Periodically check all nuts and bolts to insure they are tight and secure.
- 6) Periodically loosen torque spring bolts and allow

slip clutch to slip for approximately two (2) revolutions. Loosen the bolts until the springs lose contact with the flange yoke. This ensures that the slip clutch is not in the “locked” position.

7) Make sure that the clutch slips.

8) To retighten the slip clutch, tighten the torque spring bolts until the nut makes contact with the flange yoke and further tighten 1½ turns. This is a good starting point. Further adjustments may need to be made based on soil conditions. **NOTE:** Do **NOT** over or under tighten slip clutch assembly or damage may occur.

Storage Safety

- **Following use, or when unhooking the Tiller, disengage the PTO, stop the tractor, set the brakes, shut off the engine and remove the ignition keys.**
- **Store the unit in an area away from human activity.**
- **Do not park equipment where it can be exposed to direct contact with livestock for long periods of time. Damage to Tiller and/or livestock injury could result.**
- **Make sure all safety devices are engaged. Store Tiller on a hard, level surface in a dry environment up out of the dirt to prevent rust damage.**

ASSEMBLY, OPERATION, & MAINTENANCE INSTRUCTIONS



Decal 6



Decal 8



Decal 9

If safety decals have been damaged, removed, become illegible, or parts have been replaced without decals, new decals must be applied. New decals are available from the manufacturer. Decal sheet 16881080 includes all of the decals shown on this page. Call 888-211-0598 or online at www.ABISupport.com.

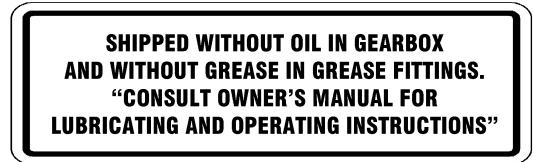

Decal 4

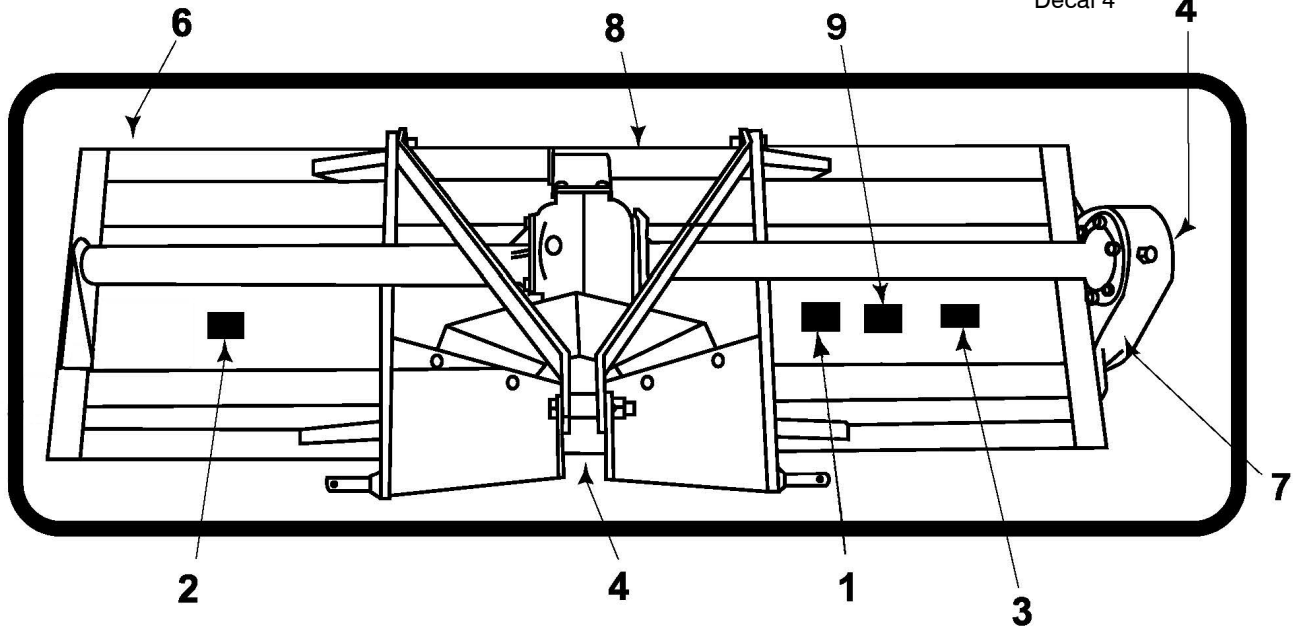

Decal 2



Decal 1



Decal 3



Decal 7

ASSEMBLY, OPERATION, & MAINTENANCE INSTRUCTIONS

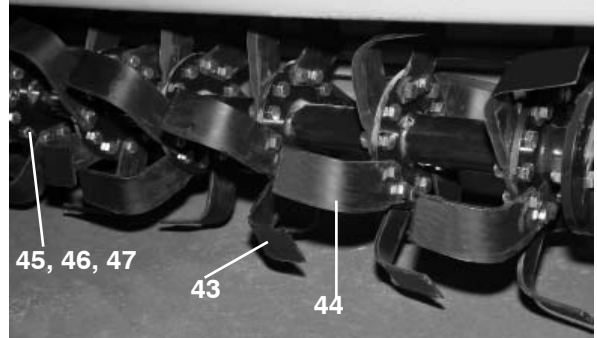
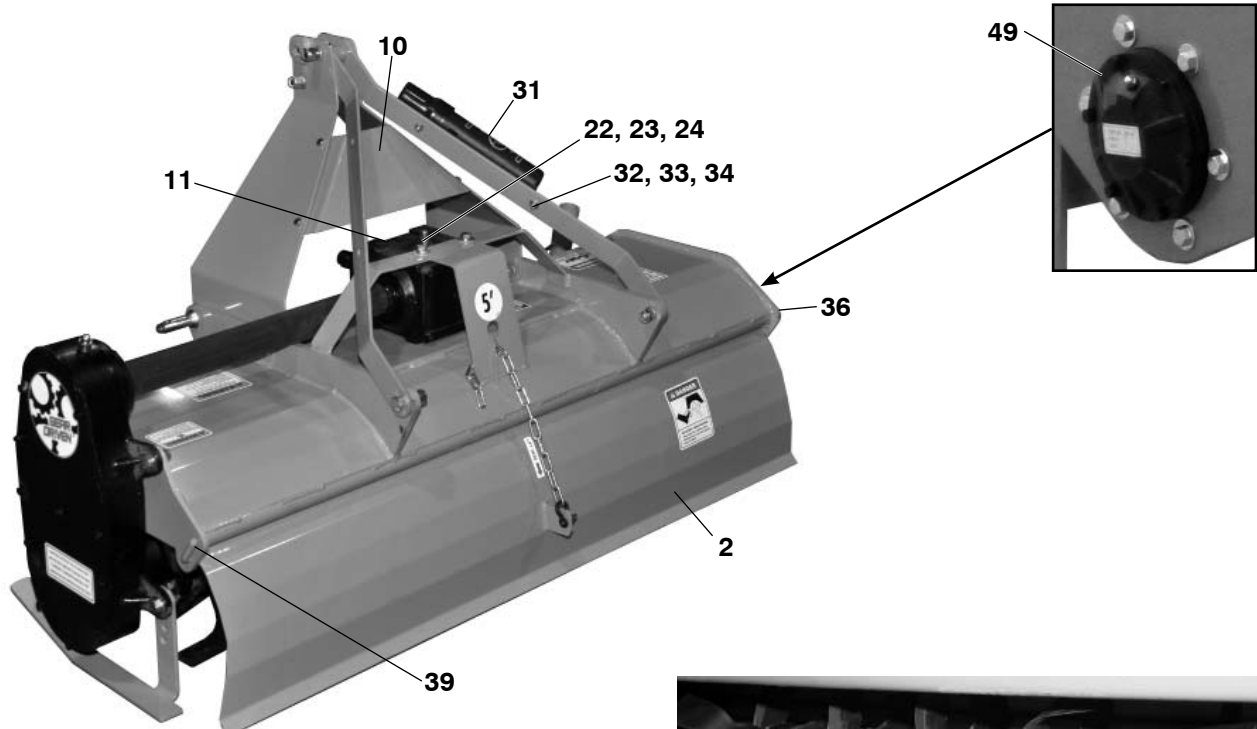
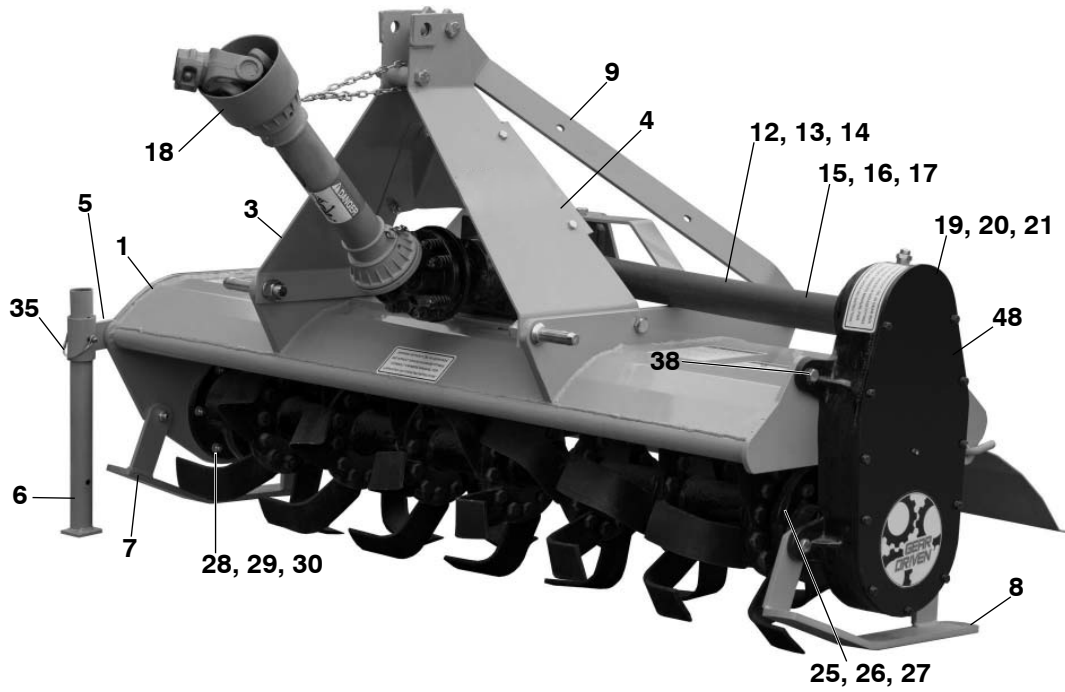

ASSEMBLY, OPERATION, & MAINTENANCE INSTRUCTIONS

No.	Part No.	Description	Qty.		
			4'	5'	6'
	80508040ABI	4' Tiller Deck Weldment	1		
1	80508050ABI	5' Tiller Deck Weldment		1	
	80508060ABI	6' Tiller Deck Weldment			1
	80408040ABI	4' Tiller Tailgate	1		
2	80408050ABI	5' Tiller Tailgate		1	
	80408060ABI	6' Tiller Tailgate			1
3	80408000ABI	Tiller Lift Arm RH	1	1	1
4	80408010ABI	Tiller Lift Arm LH	1	1	1
5	80408020ABI	Tiller Stand Bracket	1	1	1
6	80408030ABI	Tiller Stand	1	1	1
7	80650640ABI	Tiller Skid RH	1	1	1
8	80650650ABI	Tiller Skid LH	1	1	1
9	80650790ABI	Tiller Lift Brace	2	2	2
10	80650810ABI	Tiller PTO Guard	1	1	1
11	2088069	QMC Tiller Top Box H-C0100/A	1	1	1
12	2088071	QMC 4' Hex Shaft P-P1825	1	1	1
13	2088072	QMC 5' Hex Shaft P-P1902	1	1	1
14	2088073	QMC 6' Hex Shaft P-P2003	1	1	1
15	2088075	QMC 4' Plastic Tube 17½"	1	1	1
16	2088076	QMC 5' Plastic Tube 23¼"	1	1	1
17	2088077	QMC 6' Plastic Tube 29"	1	1	1
18	1728022	EC-PTO AX4-500/736	1	1	1
19	80308040	4' Rotor/Tine/Gearbox Assembly	1	1	1
20	80308050	5' Rotor/Tine/Gearbox Assembly	1	1	1
21	80308060	6' Rotor/Tine/Gearbox Assembly	1	1	1
22	3188116	Screw HHC 1/2" x 1¼" GR 5 Plated	6	6	6
23	3948002	Washer, 1/2" STD Wrought Plated	6	6	6
24	3948028	Washer, Lock Split 1/2" ZP	6	6	6
25	3188400	Bolt, Hex 1/2" x 1¾" GR 5	8	8	8
26	3948002	Washer, 1/2" STD Wrought Plated	16	16	16
27	2688381	Nut, Nylon Lock 1/2"	8	8	8
28	H00BOLTP035	Bolt HHC 3/8" x 1½" GR 5 Plated	8	8	8
29	3948204	Washer, Flat 3/8" SAE	16	16	16
30	2688063	Nut Hex Lock 3/8" Neoprene-Lined	8	8	8
31	2948019	Small Operator's Manual Holder	1	1	1
32	3188040	Bolt Hex 1/4-20 x 1 ZP	2	2	2
33	3948016	Washer STD 1/4" ZP	4	4	4
34	2688059	Nut Hex Lock 1/4" Neoprene-Lined	2	2	2
35	2868057	SQ. Lock Pin 3/8" x 3"	1	1	1

ASSEMBLY, OPERATION, & MAINTENANCE INSTRUCTIONS

36	2828006	1/8" x 1 1/2" Cotter Pin	1	1	1
37	80901000	Hardware Bag	1	1	1
38	H00BOLTP040	Bolt HHC 1/2 x 1 1/2" GR5 PLT	2	2	2
	80651140ABI	4' Tiller Tailgate Rod	1		
39	80651150ABI	5' Tiller Tailgate Rod		1	
	80651160ABI	6' Tiller Tailgate Rod			1
40	2088064	QMC 4' Rotor Ass'y	1		
41	2088065	QMC 5' Rotor Ass'y		1	
42	2088066	QMC 6' Rotor Ass'y			1
43	3018386	Tiller Tines - Lefthand	18	21	27
44	3018387	Tiller Tines - Righthand	18	21	27
45	3188401	Bolt, Hex 9/16" x 1.5 x 18 NF GR	72	84	108
46	3948209	Washer, Lock Split 9/16" ZP	72	84	108
47	2688378	Nut, Hex 9/16" x 18 NF Plated	72	84	108
48	2088068	QMC Tiller Side Box H-C0200	1	1	1
49	2088070	QMC Tiller Hub H-C300/A	1	1	1
50	3188400	Bolt, Hex 1/2" x 1.75 GR 5	8	8	8
51	3948002	Washer, 1/2" Std. Wrought Plated	16	16	16
52	2688381	Nut, Nylon Lock 1/2"	8	8	8