



---

# **ATV PULL BEHIND SPREADER**

## **OPERATION AND MAINTENANCE MANUAL**

# INTRODUCTION

## TO THE OWNER:

Read this manual before operating your equipment. Keep this manual handy for ready reference. Require all operators to read this manual carefully and become acquainted with all adjustments and operating procedures before attempting to operate the equipment. Replacement manuals can be obtained from your selling dealer.

The equipment you have purchased has been carefully engineered and manufactured to provide dependable and satisfactory use. Like all mechanical products, it will require cleaning and upkeep. Lubricate the unit as specified. Please observe all safety information in this manual and safety decals on the equipment.

For replacement parts for the centrifugal pull type spreader ATVS, the customer must use original parts offered from the manufacturer by ordering them directly from manufacturer or authorized dealer. Carrying out the order, it is necessary to have the serial number and model number from the nameplate.

Throughout this manual, the term **IMPORTANT** is used to indicate that failure to observe procedures can cause damage to equipment. The terms **CAUTION**, **WARNING** and **DANGER** are used in conjunction with the Safety-Alert Symbol, (a triangle with an exclamation mark), to indicate the degree of hazard for items of personal safety.



**This Safety-Alert Symbol indicates a hazard and means ATTENTION! BECOME ALERT! YOUR SAFETY IS INVOLVED!**



**DANGER**

**Indicates an imminently hazardous situation that, if not avoided, will result in death or serious injury.**



**WARNING**

**Indicates a potentially hazardous situation that, if not avoided, could result in death or serious injury, and includes hazards that are exposed when guards are removed.**



**CAUTION**

**Indicates a potentially hazardous situation that, if not avoided, may result in minor or moderate injury.**

**IMPORTANT**

**Indicates that failure to observe can cause damage to equipment.**

**NOTE** Indicates helpful information.

## IT IS THE PURCHASER AND/OR OPERATOR'S RESPONSIBILITY TO....

Read and understand the information contained in this manual.

Operate, lubricate, assemble and maintain the equipment in accordance with all instructions and safety procedures in this manual.

Inspect the equipment and replace or repair any parts that are damaged or worn which under continued operation would cause damage, wear to other parts, or cause a safety hazard.

Return the equipment or parts to the authorized dealer, from where it was purchased, for service or replacement of defective parts that are covered by warranty. (Manufacturer may inspect equipment or parts before warranty claims are honored.)

Payment of all costs incurred by the dealer for traveling to or transporting the equipment for warranty inspection and or claims.

Specifications .....	4
General Information .....	5-6
Safety .....	6-7
Safety Instruction Decals .....	8-9
Operation .....	10
Connecting .....	11
Adjustments .....	11-12
Loading Hopper .....	12
Spreading Fertilizer .....	13
Maintenance .....	14-15
Parts .....	16-19
Warranty .....	20

All information, illustrations and specifications in this manual are based on the latest information available at the time of publication. The right is reserved to make changes at any time without notice.

## TO THE PURCHASER:

This manual contains valuable information about your new ATV Spreader. It has been carefully prepared to give you helpful suggestions for operating, adjusting, servicing and ordering repair parts.

Keep this manual in a convenient place for quick and easy reference. Study it carefully. You have purchased a dependable and sturdy spreader, but only by proper care and operation can you expect to receive the service and long life designed and built into it.

Sometime in the future your spreader may need new parts to replace those that are worn or broken. If so, go to your dealer and provide him with the model and part number.

## CUSTOMER INFORMATION

**Name** \_\_\_\_\_

**Purchased From** \_\_\_\_\_

**Date Purchased** \_\_\_\_\_

**Model No.** \_\_\_\_\_

**Serial No.** \_\_\_\_\_

# SPECIFICATIONS

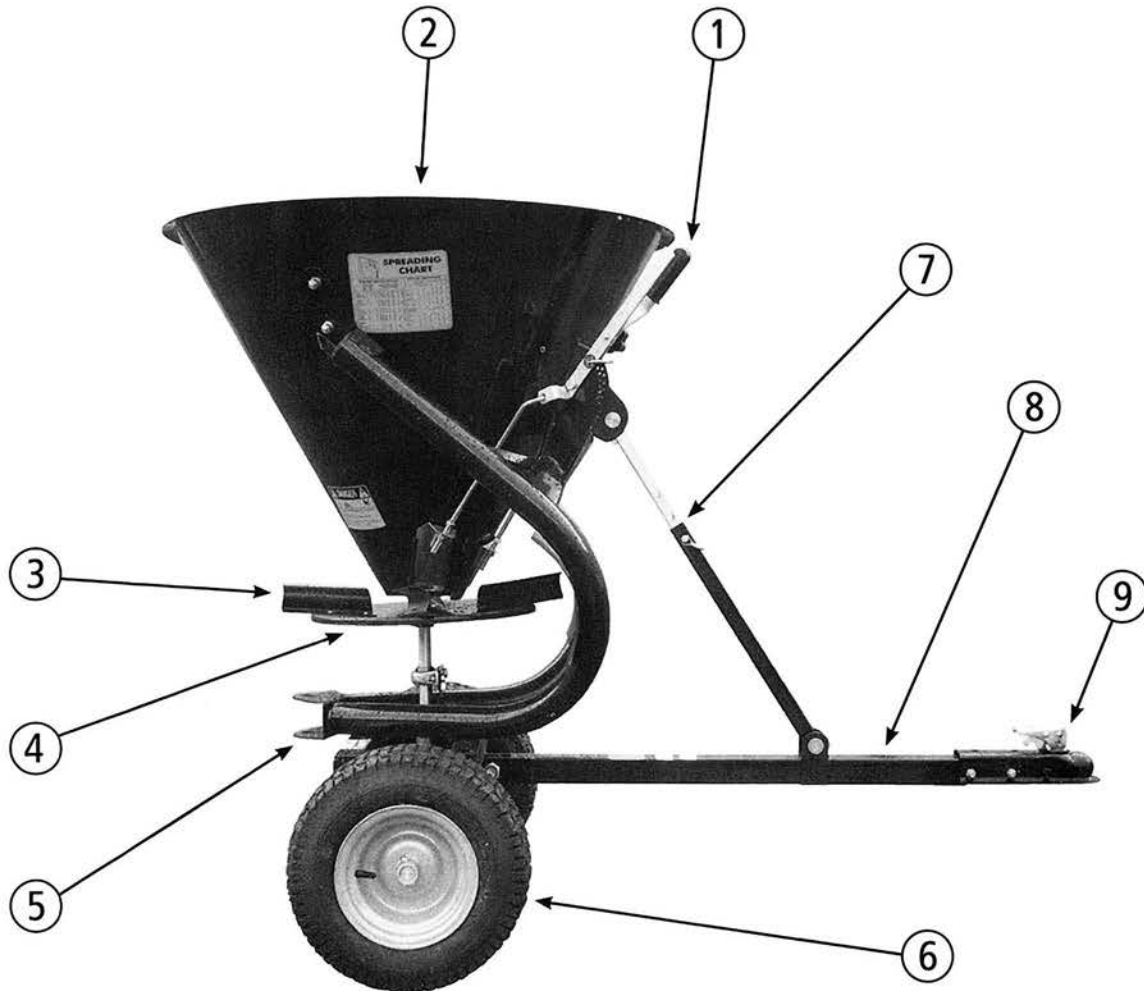

## SPECIFICATIONS

Hopper capacity (gallons)	43.6
Weight of the machine (lbs.)	175
Width (wheel, outside) (inches)	41"
Loading height (inches)	51"
Length (inches)	59"
Hopper width (inches)	35"
Ball Hitch (inches)	2"
Tires	16 x 6.5-8
Spreading width (feet)	26'-40'
Ground covered per hour	from 7 - 15 acres

1. Regulating lever
2. Hopper
3. Distributor vanes
4. Spreader disc
5. Steel frame
6. Tires
7. Leveling arm
8. Tongue
9. Tongue connection



## INTRODUCTION

The centrifugal pull type spreaders are used for the distribution of solid, granular fertilizers and seeds in the field. They can be used with small/ medium power tractors or with ATV-quad.

It is recommended to **carefully read this operator's manual**, and follow the recommendations to help ensure safe and efficient operation with the spreader. This manual has been written, in order to give the customer all the information and safety rules on the spreader, as well as to keep the spreader in good running condition.

The manual must be kept on hand in case of any questions you can refer to the manual for help and answers. It is necessary to replace the manual if it gets lost or damaged.

If there are any questions about the manual, or if the drawings/ sketches are not clear enough, please call the manufacturer or dealer of the spreader. We are always available for any questions you may have in trying to understand the manual.

## USING THIS MANUAL

This manual gives all the information for the use and maintenance of the spreader. Properly using the spreader and good maintenance will extend the life of the spreader. Some pictures in the manual show details or accessories that could be different from those of your machine, some components could be removed, in order to assure the clearness of the pictures.

Some important warning labels are put on the spreader for the safety of the customer and should remain in good visual condition. Please be aware of these labels and replace if they get faded or come off.

For replacement parts for the centrifugal pull type spreader ATVS, the customer must use original parts offered from the manufacturer (see pages 18-19 for available OEM parts) by ordering them directly from manufacturer or authorized dealer. Carrying out the order, it is necessary to have the serial number and model number from the nameplate.

## INFORMATION ON THE MACHINE

The spreader in this manual has been designed and made exclusively for distribution of solid, granular fertilizers and seeding the field. Their use is particularly indicated for the garden, lawn, and additional seeding uses. These spreaders are usually used during the day. If it is required to be used at night or with poor visibility, it must be used with a lighting system of a tractor or the equipment the spreader is connected to.

**Any modifications made to this spreader will void the warranty and relieve the manufacturer of any damages caused. Using the spreader at night is not recommended.**

## NAME PLATE

On every spreader there is a nameplate affixed with the model number and serial number. When spare parts are needed, it is very important to refer to the type of machine and the serial number on the nameplate

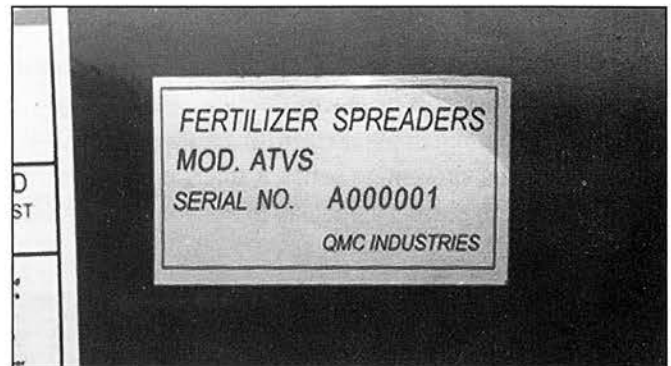

## CHARACTERISTICS OF THE MACHINE

The pull-type spreader ATVS distributes media completely with steel spreader disc with four adjustable vanes in five different positions. This model obtains the maximum spreading precision and uniformity in the distribution, depending on the kind of product that must be spread.

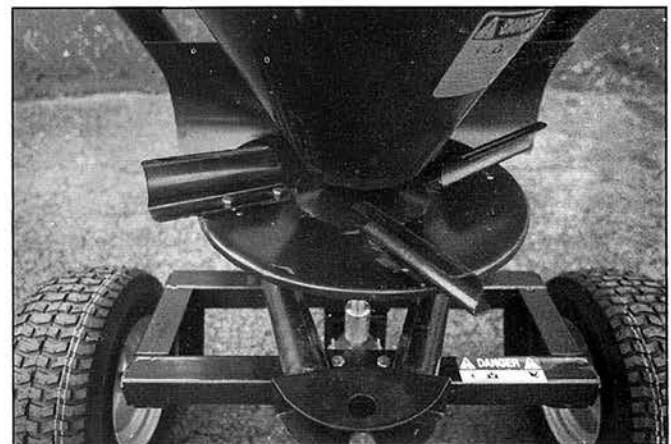

(continued on next page)

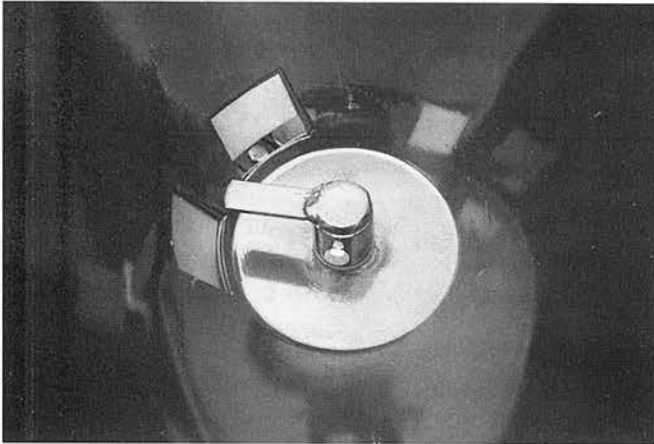

The feeding of the disc is by gravity through two openings located on the bottom of the hopper, inside of which an agitator is applied, preventing lumps. A shield is placed in front of the disc to prevent spreading in the front side of the spreader.

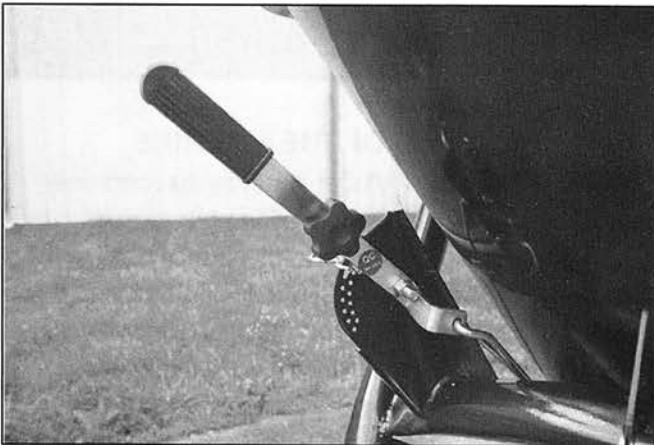

The media delivery is controlled by properly opening the shutters in the hopper bottom, through lock devices operated by a lever. The spreader and the agitator are connected through a gear box on the axle between the wheels, so as to allow a speed of the disc, directly proportionate to the speed of the spreader. To activate disc, pin must be placed in axle and to stop rotation you must remove the pin.

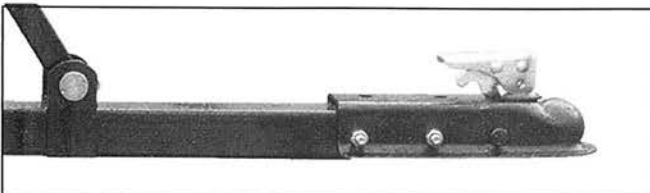

## **IMPORTANT SAFETY INFORMATION**

**The following safety recommendations are to insure your safety: Therefore it is necessary to read them carefully, memorizing and always applying them.**

**The present warnings in this manual are exclusively how to use the spreader safely. All below instructions must be integrated by common sense and by people with experience in working with the spreader and work safety to prevent accidents.**

The spreader must be used by a single operator, 18 years or older. All the listed instructions must be carefully respected.

Any modifications or changes to the spreader without written authorization from the manufacturer excludes the manufacturers of any and all liabilities.

### **CHECK THE CORRECT FUNCTIONING OF THE MACHINE, BEFORE EACH USE.**

#### **General Advice:**

- **Read this manual carefully before proceeding to start, operate, or maintain the spreader.**
- The manual must always be handy, so as to consult it, in order to check the working cycle and safety information. In case of loss or damage, it will be necessary to ask for another copy.



**WARNING**

**Any maintenance work or cleaning must be done with the spreader on the ground (in stable conditions), turn engine of tractor or ATV-quad off and remove key.**

- All safety labels must be followed. If warning labels are not readable because of wear and tear, warning labels should be replaced as shown on page 8-9.

(continued on next page)

**WARNING**

**The operator, during the period of use, maintenance, repair, handling or storing of the spreader, must wear proper safety attire and follow safety instructions as listed in the manual.**

- During loading phase, there is the danger of powder inhalation produced by fertilizer mixing. It is suggested to use tractors with filters in the ventilation system of the cabin, or use suitable safety masks like powder masks or masks with filters.
- The spreader is designed for being used by a single operator who, during the use, must always stay in the drivers seat.
- Never work with this spreader if you are tired, sick or under the influence of alcohol, drugs, or medication.

**DANGER**

**Climbing on the hopper or transporting someone when the spreader is in motion is forbidden. Do not let anyone inside the hopper for any reason.**

- Keep the spreader clear of foreign bodies (debris, tools, rocks, miscellaneous items), as they could damage the spreader as well as the operator. **Unit should be cleaned after each use due to possible corrosiveness of material spread. Clean the hopper and the distributor after each use of the spreader.**
- Check tractor or ATV-quad to insure that it is in good working condition prior to connecting the spreader.
- Before connecting or disconnecting spreader to a tractor or ATV ensure that the spreader is stable on compact and level ground and hopper is empty.

**WARNING**

**During transport, operation, stocking, and servicing operators must follow all safety warnings and labels for all equipment involved at all times.**

**NOTE**

**The Manufacturer and distributor is not liable for damages or injury caused by improper use of the spreader.**

**THE MANUFACTURER IS NOT RESPONSIBLE IN CASE OF:**

- Improper use of the spreader
- Not keeping the spreader well maintained
- Using parts not specific to the product
- Not following all the instructions
- Not following all rules during use

**SAFETY AND INSTRUCTION DECALS**

**ATTENTION! STAY ALERT! YOUR SAFETY IS INVOLVED!**

Replace Immediately if Damaged!

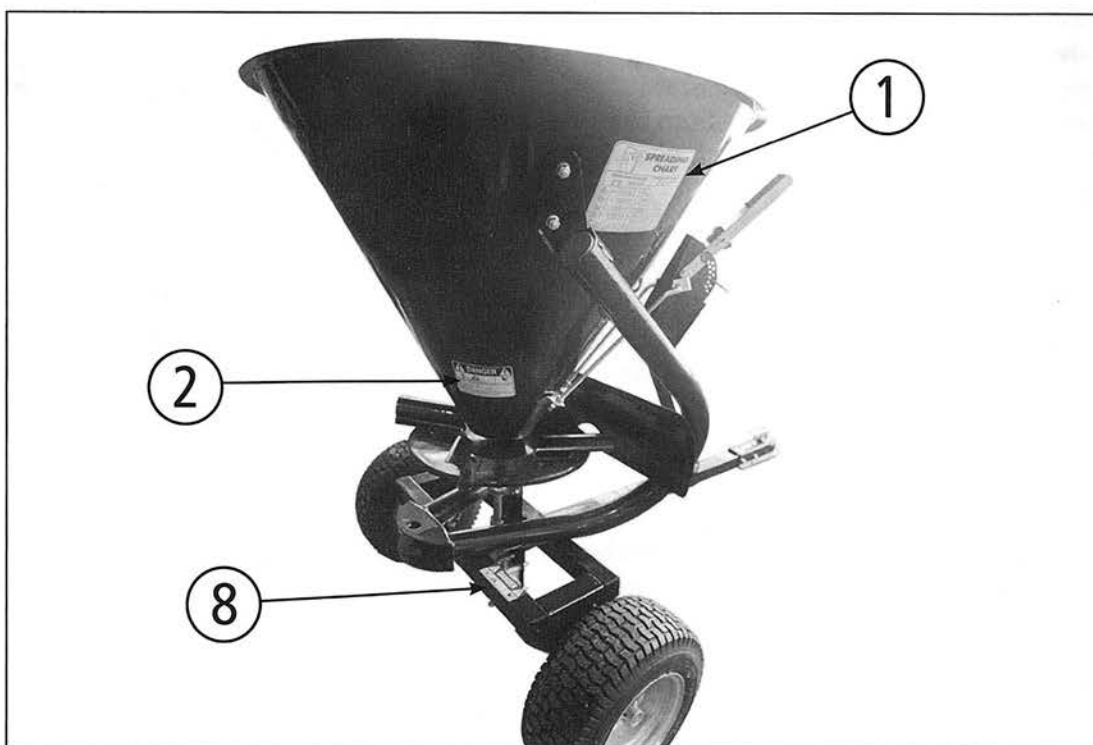
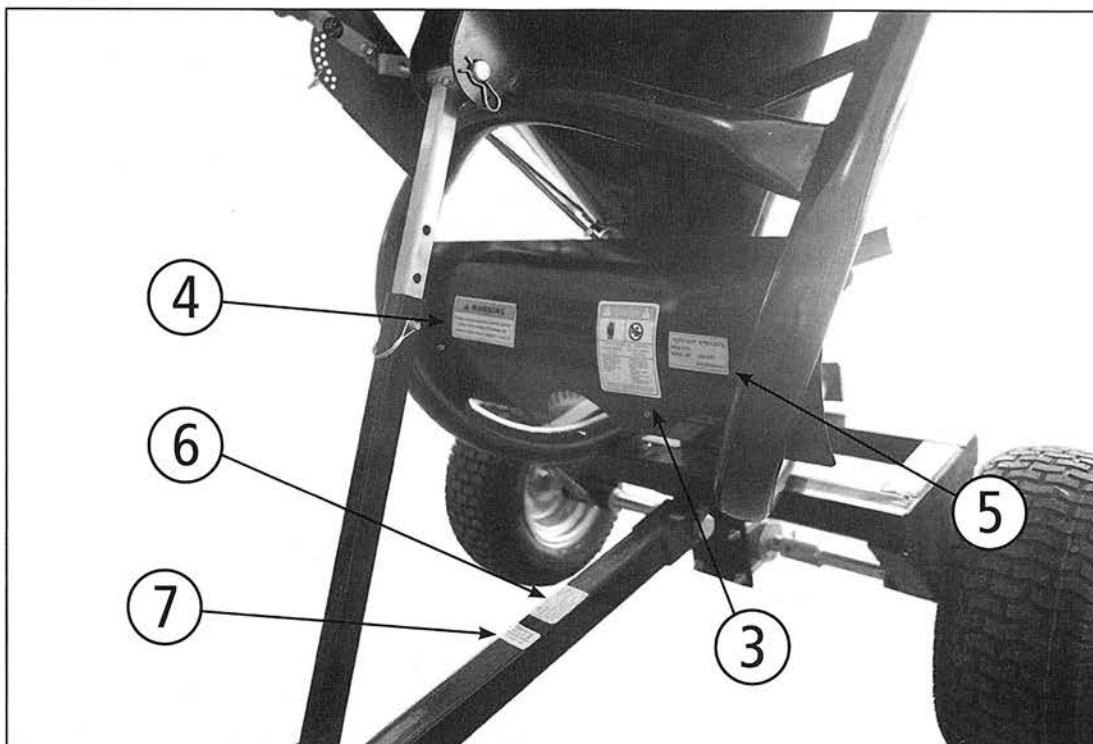





ATTENTION! STAY ALERT! YOUR SAFETY IS INVOLVED!

Replace Immediately if Damaged!

**1**

## SPREADING CHART

SPREADING CHART FOR FERTILIZER										SPREADING CHART FOR SEED									
TRACTOR WORKING SPEED (MPH)	WIDTH (FEET)	QUANTITY SPREAD IN LBS/ACRE AT VARIOUS GATE SETTINGS								WHEAT	ALFALFA & CLOVER	FESCUE & RYEGRASS	RED CLOVER	KENTUCKY BLUE GRASS & PERENNIAL GRASS	SUDAN GRASS	BANYAN	RYE		
		1	2	3	4	5	6	7	8										
LARGE GRANULAR FERTILIZER 2.5	132	245	402	625	829	1014	1140	1248	3	32	0	48	128	258	388	518	648		
LARGE GRANULAR FERTILIZER 5.0	66	122	201	312	414	507	570	624	3	16	0	24	64	129	194	258	324		
LARGE GRANULAR FERTILIZER 7.5	44	82	134	212	280	338	380	418	3	11	0	16	42	84	118	152	186		
MEDIUM GRANULAR FERTILIZER 2.5	—	311	448	709	925	1025	1118	1182	3	19	0	28	72	144	216	288	360		
MEDIUM GRANULAR FERTILIZER 5.0	83	—	156	224	355	453	513	559	3	9	0	14	36	72	108	144	180		
MEDIUM GRANULAR FERTILIZER 7.5	—	104	149	237	300	342	373	396	3	6	0	10	24	48	72	96	120		
FINE GRANULAR FERTILIZER 2.5	112	189	322	529	747	842	903	1001	3	12	0	18	48	96	144	192	240		
FINE GRANULAR FERTILIZER 5.0	40	56	95	140	205	274	321	351	3	6	0	9	24	48	72	96	120		
FINE GRANULAR FERTILIZER 7.5	—	37	53	81	111	137	160	177	3	4	0	6	16	32	48	64	80		
CRYSTAL (AMMONIUM SILPHATE) 2.5	230	369	600	800	1036	1254	1532	1832	3	32	0	48	128	258	388	518	648		
CRYSTAL (AMMONIUM SILPHATE) 5.0	115	184	300	400	518	627	766	916	3	16	0	24	64	129	194	258	324		
CRYSTAL (AMMONIUM SILPHATE) 7.5	76	123	187	267	342	411	507	544	3	11	0	16	42	84	118	152	186		
TICHAAS BEAL (BASIC SLAND) 4.0	29	—	—	571	—	1270	—	1885	3	8	0	12	30	60	90	120	150		
TICHAAS BEAL (BASIC SLAND) 8.0	—	—	—	285	—	635	—	843	3	4	0	6	15	30	45	60	75		

**4**

### WARNING

Always keep away from rotating spinner.  
Never work on top of or inside the hopper unless tractor engine is shut off.

**5**

Fertilizer Spreaders  
Mod. ATVS  
Serial NO. A000001  
QMC Industries

**2**

## DANGER

### THROWN OBJECT/ROTATING PADDLES HAZARD

To prevent serious injury or death:  
-Keep away from discharge area and rotating paddles during operation.  
-Keep others away.  
-Disconnect and lockout power source BEFORE adjusting or servicing.  
-DO NOT point discharge towards people, animals, or buildings when operating.  
-Keep hands, feet, hair, and clothing away from moving parts.

**6**

Check grease every 8 hours of work

005

**3**

## DANGER

### TOXIC CHEMICAL HAZARD

WEAR RUBBER GLOVES DO NOT INGEST CHEMICAL

Do not allow chemicals or solutions to touch skin. Some can be absorbed through the skin. Wear rubber gloves and protective gear at all times.

Chemicals can be toxic if in eyes or mouth, read chemical manufacturer's instructions and follow label. Seek medical attention immediately. A poison control number is normally inside the front cover of your telephone book.

FAILURE TO FOLLOW THESE INSTRUCTIONS WILL RESULT IN SERIOUS INJURY OR DEATH

**7**

## Warning

UNIT MUST BE GREASED PRIOR TO FIRST USE

**8**

## DANGER

# OPERATING

## OPERATION OF THE SPREADER

- Check the spreader before use. Only use if it is in good working condition.
- Before using the spreader, be sure that all safety devices are correctly placed and in case of any breakdowns or damage to the protective guard, replace it immediately.



### CAUTION

**During work, please be sure that for a radius of 162 feet there are no obstacles including people or animals. When you work in proximity of roads or public places, it is ABSOLUTELY MANDATORY to keep away from people and to increase your precautions.**



### DANGER

**The operator must prevent coming into the danger area and to work with maximum caution. If anybody comes up, please stop the tractor or ATV-quads's engine immediately.**

- Before every use of the spreader, please always check the wear of the vanes and the spreader disc. Check that all the hardware are in place and tight.
- Never leave the spreader unattended while moving.
- Keep the spreader in good operating condition and perform regular maintenance checks.

## TRANSFER ON THE ROAD



### CAUTION

**Not for highway use or transport.**

Remember that while moving on public roads, special attention is required, which is noted on the registration book of the tractor or ATV-quad. Choose an appropriate speed especially when the street is crowded, winding or sloping.

If the spreader hides the back signaling lights of the tractor or ATV-quad, it is necessary to put a light bar and/or some back signaling sign.

While moving spreader from a working location to another, the gearbox must be disengaged by removing pin from axle stopping rotation of the disc as shown in the picture.

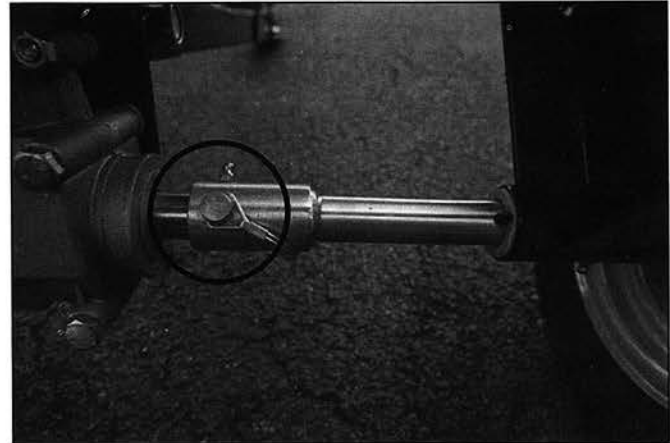

### WARNING

**Before use, please check that gear box and all zerks adequately greased (see page 14).**



### CAUTION

**During the use of the machine, be sure that for a radius of 162 feet there are no people or animals. If anyone comes up, please stop the tractor or ATV-quad engine immediately.**

### Recommendations for correct distribution

- Please test the lb./acre that you wish to spread before starting to work.
- When spreading in humid conditions, a humid media could not be spread uniformly or correctly. Clogging and inaccurate distribution will occur.
- Avoid spreading during windy days, in order to improve the uniformity of the distribution.

(continued on next page)

## CONNECTING

The spreader (ATVS) can be hitched to most type of tractor or ATV-quad with a 2" ball. To make the connection, it is necessary to put the ball hitch in the coupler on the spreader, locking it by pushing the lock handle towards the bottom. Check and regulate the length of the leveling arm, so that the spreader disc is, as parallel as possible, to the ground, in order to get a uniform and regular distribution of your media.

Remove the spring pin, as shown with the arrow in the picture below and move the leveling arm in to the optimal position, in correspondence with the present holes and replace the pin in the new position.

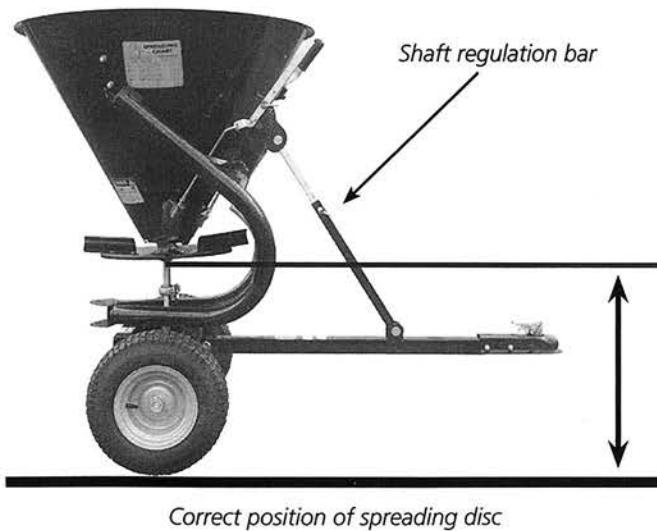

## HOW TO ADJUST THE SPREADER VANES

In order to assure an even distribution on both sides of the spreader, depending on the different specific weight of the media used, the distributor vanes on the disc can have a different position. When all the vanes are put in hole 1 (as shown in the picture), the distribution of the media is increased towards the left, compared to the way the tractor is moving. If the vanes are put in hole 5, the distribution will be more towards the right. When moving the vanes from 1 to 5 on the same speed, there will be an increase of the distributing width. This adjustment must be made according to the type of media used.

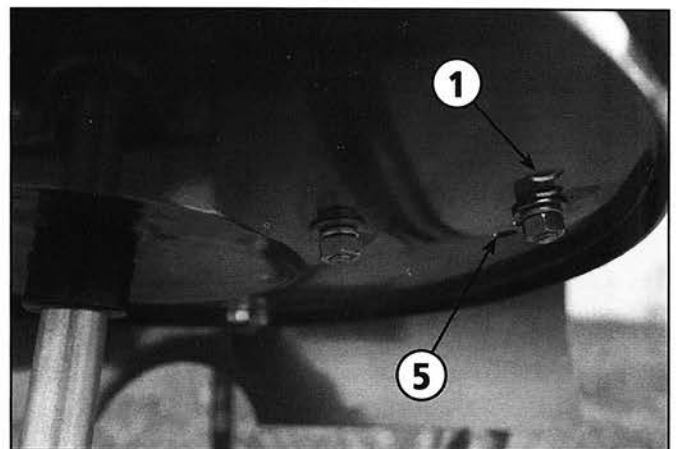

Spreading disc's distributor vanes regulation

## ADJUSTMENTS

It is not possible to have an exact spreading chart for the centrifugal equipment, as the distributed quantity depends on the speed, on the radius of distribution, on the quality and humidity of the media and on the roughness of the land. The media must always be stored properly to keep its physical characteristics unchanged. It is necessary to set the regulation lever of the spreader, before starting the operation of distribution, adding in the possible limits, to keep it constant for all its duration. The spreading charts contain the information, in order to determine the quantity to spread in the field; these must be completed by competent operators.

(continued on next page)

# ADJUSTMENTS / LOADING HOPPER

## HOW TO ADJUST THE SPREADER

The spreading is controlled through the regulation lever that moves the opening section on the bottom of the hopper. After consulting the spreading chart, it is necessary to move lever "A" along the graduated scale "E" and blocking it in the chosen position with the pin "D".

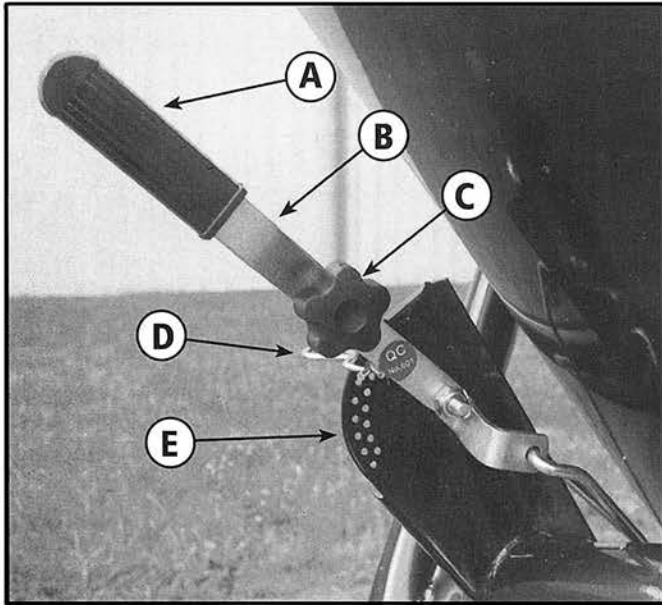

In order to spread from both sides (position 1), "A" and "B" (not visible in picture) levers must be in the same position, connected through the knob "C". In order to carry out the spreading only through the left side (position 2), it is necessary to disconnect the two levers removing the "C" knob, set lever "B" (not visible in picture) in the chosen position, given by the spreading chart, and bring lever "A" towards the higher part in order to close the shutter of the right side. In order to spread only one on to the right side (position 3), you have to move lever "B" (not visible in picture) up, in and regulate the quantity to spread with lever "A".

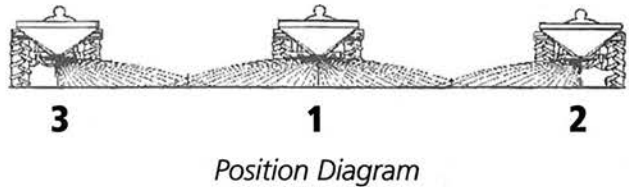

## HOPPER LOAD

It is advised, not to carry out the hopper loading manually, but to use a lifter or suitable mechanical means.

## SPREADING CHART

SPREADING CHART FOR FERTILIZER										SPREADING CHART FOR SEED											
TRACTOR WORKING SPEED (MPH)		WIDTH (FEET)		QUANTITY SPREAD IN LBS/ACRE AT VARIOUS GATE SETTINGS								TRACTOR WORKING SPEED (MPH)		WIDTH (FEET)		QUANTITY SPREAD IN LBS/ACRE AT VARIOUS GATE SETTINGS					
2	3	4	5	6	7	8	8.5	9	10	11	12	13	14	15	16	17	18	19	20		
LARGE GRANULAR FERTILIZER										WHEAT											
2.5	132	245	462	635	929	1014	1140	1248		3	52	0	45	129	268						
6.0	66	123	231	318	465	507	570	624		5	26	0	23	77	161						
7.5	44	82	154	212	310	338	380	416		7	16	0	15	70	148	277					
MEDIUM GRANULAR FERTILIZER										ALFALFA & CLOVER											
2.5	-	211	446	709	925	1025	1118	1182		3	43	0	43	143	309	545					
6.0	-	106	224	355	463	513	569	611		5	22	0	22	75	204	367					
7.5	-	70	149	237	309	342	373	394		7	15	0	15	70	148	277					
FINE GRANULAR FERTILIZER										FESCUE & RYEGRASS											
2.5	112	189	322	529	747	842	963	1051		3	18	0	18	69	161						
6.0	56	95	169	265	374	421	482	526		5	9	0	9	35	87						
7.5	37	63	111	177	249	280	321	351		7	6	0	6	23	60						
CRYSTAL (AMMON. SULPHATE)										RED CLOVER											
2.5	226	369	609	800	1236	1354	1522	1632		3	31	44	167	333	642						
6.0	113	184	304	400	618	677	761	816		5	16	26	100	206	394						
7.5	75	125	187	267	412	461	507	544		7	10	19	72	143	276						
THOMAS MEAL (BASIC SLAG)										KENTUCKY BLUE GRASS & BERBERIS GRASS											
4.0	39	-	-	571	-	1270	-	1655	-	3	30	0	49	131	271						
6.0	-	-	-	285	-	635	-	843	-	5	15	0	29	79	163						
										7	10	0	21	58	116						
										SUDAN GRASS											
										3	12	0	12	45	93						
										5	6	0	6	22	45						
										7	4	0	4	15	30						
										BARLEY											
										3	40	0	40	151	301						
										5	20	0	20	75	150						
										7	14	0	14	51	102						
										RYE											
										3	40	0	40	151	301						
										5	20	0	20	75	150						
										7	14	0	14	51	102						

**WARNING**

The hopper must be loaded only after having hitched the spreader to the ATV-quad.

Do not drive for long distances with a full load. Do not put full bags of media in the hopper during transportation or during spreading. Do not overload the capacity of the spreader and compress the media.

(continued on next page)

## SPREADING MEDIA IN THE FIELD



### WARNING

The operator must wear proper safety attire during periods of use, maintenance, repair, transport, or storing of the spreader.

After having hitched the spreader to the ATV-quad/tractor and having carried out the necessary adjustments, it is possible to begin work.

Engage the axle with the pin, so that the spreader can begin rotating by turning wheels, only when you are ready to use the spreader.

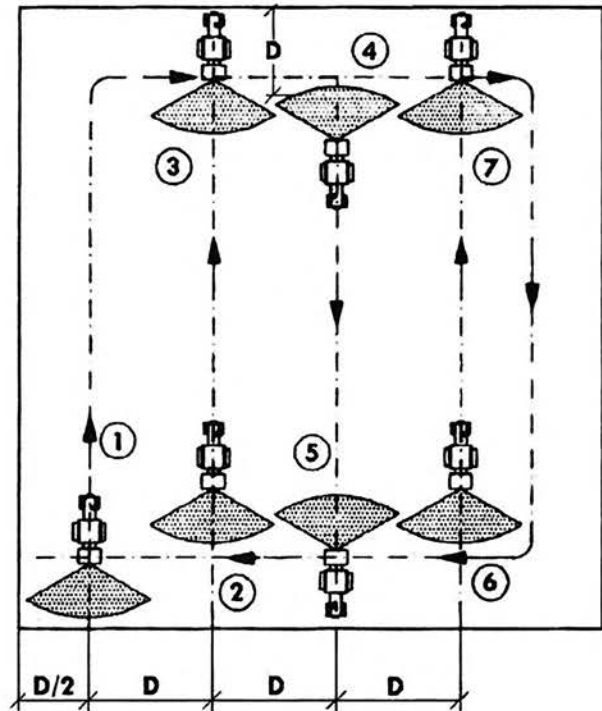
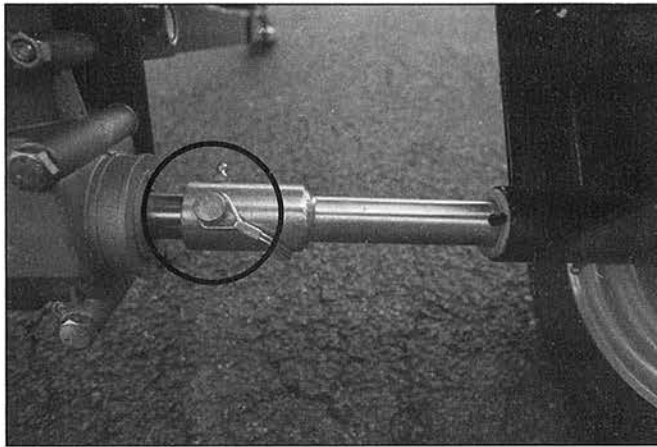

## SPREADING MISTAKES

### COMMON MISTAKES

- Drive speed
- Incorrect spreading width
- The spreading disc is not in a horizontal position compared to the land
- Drive speed is different to those suggested by the spreading tables, or not suitable for that particular type of media
- Lack of cleaning on vanes and disc

There are various ways to spread media in the field. One of the simplest methods is as follows:

- Positioning the ATV-quad/tractor at the beginning of the field you intend to work, to a distance ( $D/2$ ) that is the half of the working width that is used (point 1)
- Driving in the field distributing the media on all the perimeter
- Stopping the ATV-quad/tractor at one distance ( $D$ ) from point 1, equivalent to the set working width (point 2)
- Beginning the spreading proceeding in line, straight to point 3
- Turn the ATV-quad/tractor and drive a ( $D$ ) distance, equal to the working width (point 4)
- Repeat procedure until all the plot is covered

(continued on next page)

# MAINTENANCE

## MISTAKES DUE TO MEDIA

- Poor quality media
- Wet or very humid media
- Incorrect media composition or it does not correspond to what is suited for spreader
- Presence of excessive media clumps may cause negative yield on spreading
- Debris in the media

## MISTAKES DUE TO THE SPREADER

- Spreading exits clogged
- Parts of the spreading discs assembly worn away or damaged

## GENERAL MAINTENANCE

The general maintenance criteria we suggest are based on company experience and on advice and suggestions from customers. A good maintenance routine keeps operating costs low and allows for a long spreader life.

### WARNING

**When working on spreader, whether for maintenance, repair or cleaning, spreader must be on the ground in stable conditions, ATV-quad/tractor's engine should be turned off, brakes set, keys turned off and removed from ignition.**

If damage occurs, the operator must stop the spreader immediately, assess the problem, and proceed with proper actions to fix the spreader. Do not use flammable fluids.

### WARNING

**When doing maintenance, always wear proper safety attire and follow safety steps in the manual.**

In case of unusual vibrations, verify the conditions of the distributor on the spreading disc, the tightness of all the nuts and bolts and the lubrication of the gear box. For every 8 hours of spreading time, tighten all nuts and bolts. Any excessive vibration of the machine is dangerous and damaging for the entire spreader.

## LUBRICATION

Before every use and after every 8 hours of spreading, you must grease the spreader. Be sure that the grease zerks are clean from dirt and debris before injecting with grease. Lubricate with lithium grease at the points, shown in the picture.

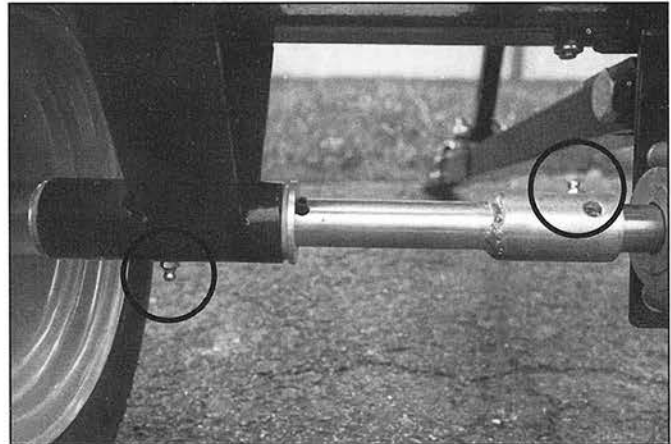

Fill gearbox with "00" grease before use. To access gearbox, flip spreader over. Located in the middle of the gearbox is the plug (pictured below). Remove plug and fill gearbox until full.

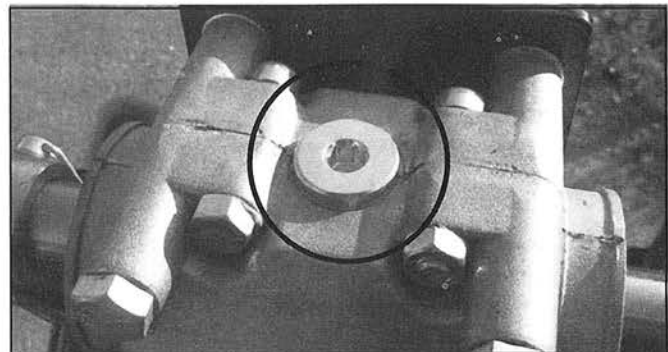

## REPLACEMENT OF THE DISTRIBUTOR VANES

If the distributor vanes of the disc brake or get damaged, it is necessary to replace them with new ones. Unscrew the nuts and replace the damaged vane.

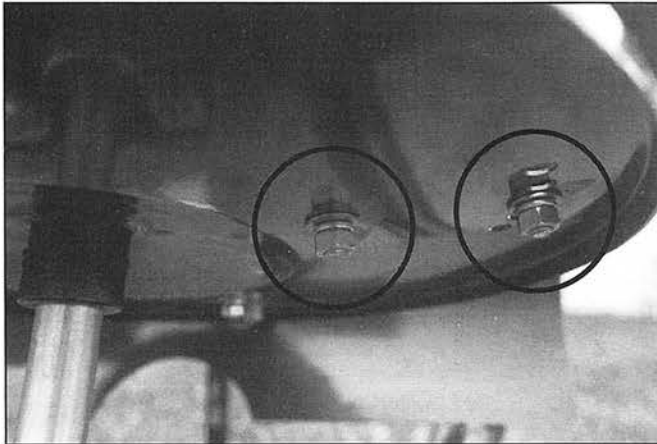

## SPARE PARTS

For replacement parts for the spreader, the customer must use original parts offered (see page 18-19 for serviceable parts list) from the manufacturer by ordering them directly from manufacturer or authorized dealer. When ordering, it is necessary to have the serial number and model number from the nameplate.

## STORAGE

It is good practice to keep up maintenance and fix repairs. Store the spreader in a dry sheltered place, away from any chemicals. Fertilizers are generally corrosive, for this reason, it is important that no particles remain in the spreader for long periods of time. Before storing the spreader, it is important to:

- Thoroughly wash the spreader and inside the hopper
- Look over the spreader in order to check for any structural damages
- Verify that the safety labels are present, clean and readable, if not replace them
- Grease all mechanical parts (see page 14)

# PARTS

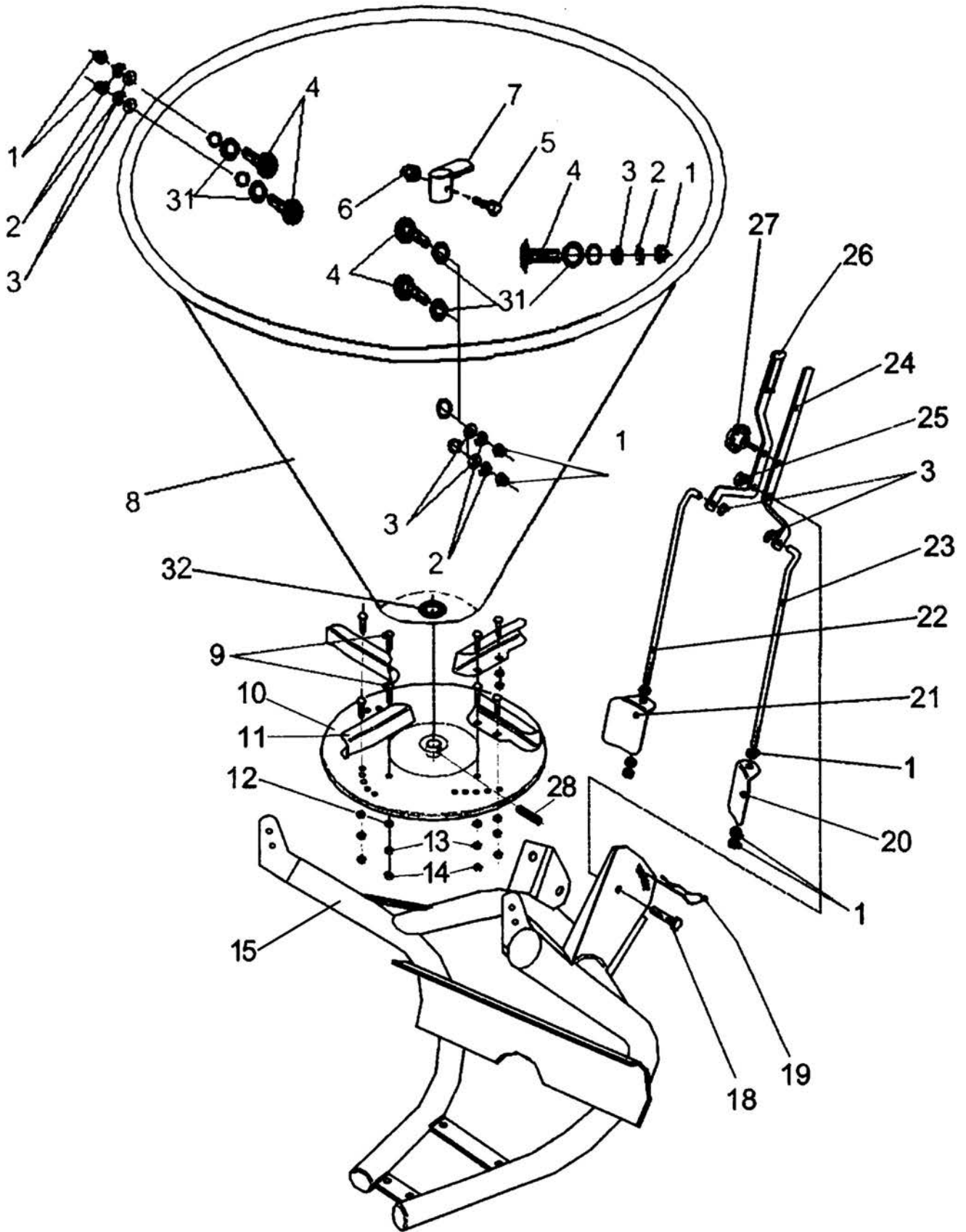



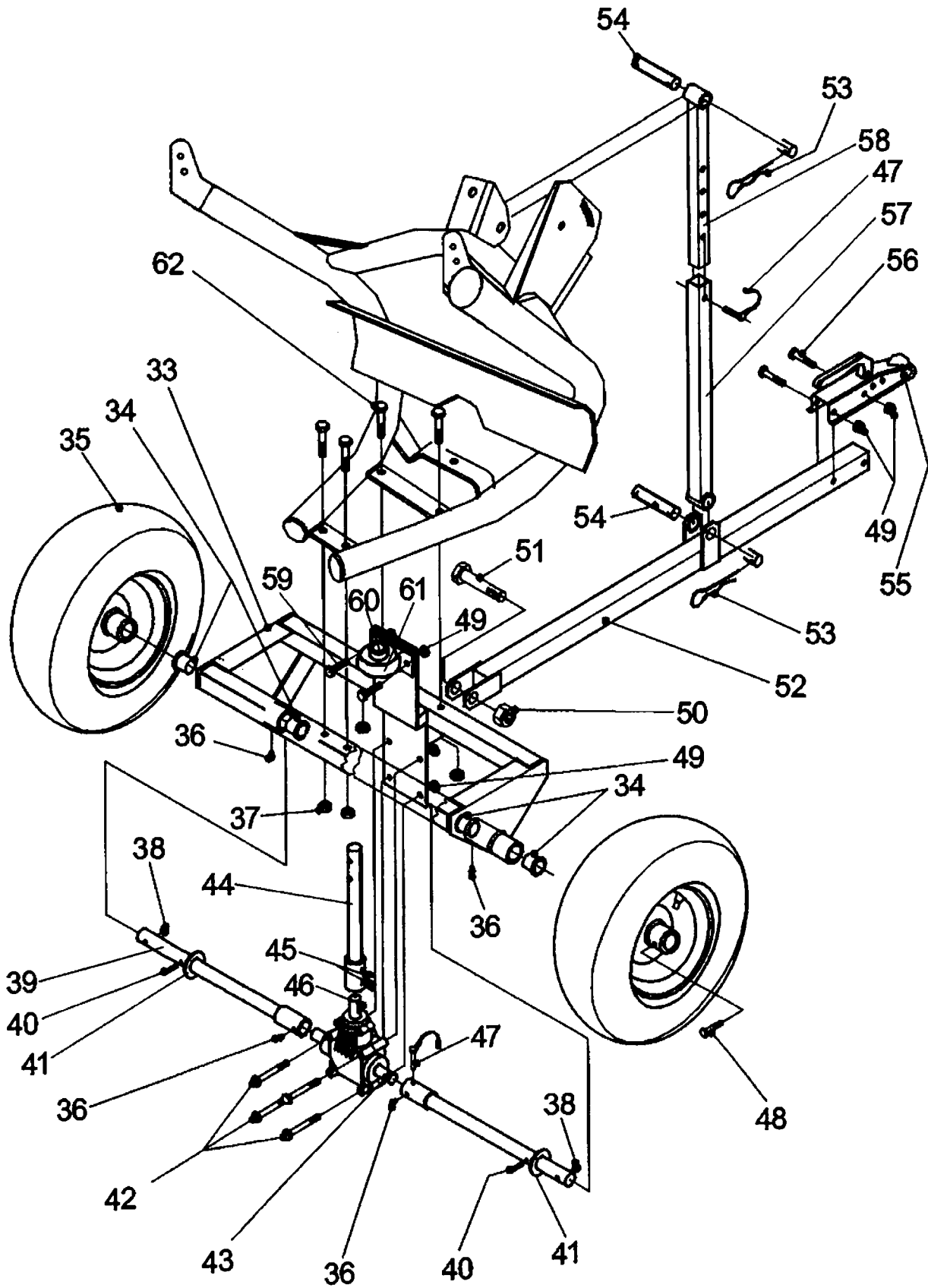

# PARTS

## ATVS Service Part List

Ref. #	Description	Part #	Service
1	M10 Zinc Hex Nut		No
2	10mm Zinc Lock Washer		No
3	10mm Zinc Flat Washer		No
4	M10 X 25 Zinc Snap Head Bolt		No
5	M8 X 45 Zinc Hex Head Bolt		No
6	M8 Zinc Self-Locking Nut		No
7	ATVS Agitator	996M	Yes
8	ATVS Hopper Tub (5 bu)	997M	Yes
9	M8 X 16 Zinc Hex Head Bolt		No
10	ATVS Spreading Disc (Spinner)	681M	Yes
11	Distributor Vane	671M	Yes
12	8mm Zinc Flat Washer		No
13	8mm Zinc Lock Washer		No
14	M8 Zinc Hex Nut		No
15	ATVS Frame		No
18	M12 X 35 Zinc Hex Head Bolt		No
19	4.5mm Zinc Split Pin		No
20	Left Shutter	766M	Yes
21	Right Shutter	767M	Yes
22	Right Tie Rod	768M	Yes
23	Left Tie Rod	769M	Yes
24	Left Lever	770M	Yes
25	M12 Zinc Self-Locking Nut		No
26	Right Lever	772M	Yes
27	Lever Lock Knob	773M	Yes
28	8 X 45 Spring Pin		No
31	Spreader Hopper Washer		No
32	Rubber Sleeve	991M	Yes
33	ATVS Support Frame	998M	Yes
34	Nylon Bearing	999M	Yes
35	PTP Tire 16 X6.50-8	1000M	Yes
36	M8 Grease Fitting		No
37	M12 Zinc Self-Locking Nut		No
38	M8 Zinc Self-Locking Nut		No
39	PTP Axle	1001M	Yes
40	5 X 40 Spring Pin		No
41	25 X 44 X 2 Zinc Flat Washer		No
42	M10 X 100 Zinc Hex Head Bolt		No
43	ATVS Output	1002M	Yes
44	ATVS Output shaft with Bushing	1003M	Yes
45	M8X 8 Bolt		No
46	8X 25 Key		No
47	8X 55 Safty Pin		No
48	M8X 50 Zinc Hex-Socket Head Bolt		No
49	M12 Zinc Self-Locking Nut		No
50	M20 Zinc Self-Locking Nut		No

51	M22 X 80 Zinc Hex Head Bolt		No
52	Assembly Tube	1004M	Yes
53	3mm Zinc Split Pin		No
54	22 X 80 Zinc Pin	1005M	Yes
55	2" Coupler		No
56	M10 X 70 Zinc Hex Head Bolt		No
57	Leveling Arm Outer Tube	1006M	Yes
58	Leveling Arm Inner Tube	1007M	Yes
59	M10 X 25 Zinc Hex Head Bolt		No
60	UC 205 Bearing	1008M	Yes
61	PP205 Bearing Seat	1009M	Yes
62	M12 X 75 Zinc Hex Head Bolt		No

# WARRANTY

## WARRANTY

The manufacturer warrants to the original purchaser that the implement is free from defects in both material and workmanship under normal use and service for a period of one (1) year for noncommercial use. Any use by commercial, state, and municipalities will void warranty.

This Warranty shall not be interpreted to render the Manufacturer liable for damages of any kind, direct, consequential, or contingent to property. Furthermore, Manufacturer shall not be liable for damages resulting from any cause beyond its reasonable control. This Warranty does not extend to loss of crops, any expense or loss for labor, supplies, rental machinery, or for any other reason.

This Warranty does not apply to any part or product which in the Manufacturer's judgment shall have been misused or damaged by accident or lack of normal maintenance or care, or which has been used for purpose for which the product is not designed. Manufacturer reserves the right to make changes in materials or design of the product at any time without notice.

This Warranty is extended solely to the original purchaser of the product. Should the original purchaser sell or otherwise transfer this product to a third party, this Warranty does not transfer to the third party purchaser in any way. There are no third party beneficiaries of this Warranty.

Warranty specifications:

- Must show proof of purchase within 1 year of purchase date.
- Photos must be provided to ensure proper warranty claim.
- Claims under this Warranty must be made to an authorized dealer, and must be submitted within 30 days of failure.

The above information must be provided in order for us to process your claim and for you to receive a Return Manufacturers Authorization # (RMA) from manufacturer. Any product determined to be defective and has been issued an RMA # by the manufacturer will be picked up and returned to our facility for complete inspection and disposition of liability. Once a warranty claim is accepted, the manufacturer will issue full credit or exchange the product at no cost to the store or customer.

### KEEP FOR YOUR RECORDS

Record the model number, serial number, and the date of purchase with original sales receipt. This information will be helpful to your dealer if parts or service are required.

**MODEL NUMBER** \_\_\_\_\_

**SERIAL NUMBER** \_\_\_\_\_

**DATE OF PURCHASE** \_\_\_\_\_

**DEALER** \_\_\_\_\_

