

Energy-Free Waterers

SF-2C, SF-4C, EF-2C, EF-4C

THANK YOU FOR PURCHASING THIS PRODUCT

Behlen Country has been in the business of providing quality products for more than 80 years. Our products will provide many years of service when maintained by the owner and used in accordance with the capabilities of the product. For questions about this product, or for parts inquiries, please contact our Customer Service Center listed below.

CONGRATULATIONS, you have just purchased one of the most efficient Energy-Free waterers ever manufactured.

The thermos bottle type construction will hold the heat from the earth temperature of the water and keep your Energy-Free waterer warm in the winter and cool in the summer. The enclosed dark interior inhibits growth of bacteria, scum and algae.

The smooth rounded plastic exterior is maintenance free and prevents injuries to animals. It also prevents tongue injuries from frigid steel.

All Behlen Country Energy-Free Waterers carry a 5 year limited warranty on the body and a 1 year limited warranty on valves and controls.

Installation and Recommendations

Please read over these instructions to make sure you have all necessary components for your installation. To ensure proper operation in cold weather, it is highly recommended that you purchase the optional Poly Earth Tube and Shut-off Valve Kit. Contact your dealer for necessary items.

The Energy-Free waterer depends on water entering the unit at ground temperature (50-55° F.). This generally requires the 3/4" water line to be at least 2 ft. below the frost line for maximum performance.

Also, a minimum number of animals must use the waterer to ensure that enough fresh water is cycled through the waterer daily to prevent freezing.

Energy-Free Waterer	Minimum Number of Animals	Gallon Capacity
SF-2C	20	40
SF-4C	30	80
EF-2C	20	20
EF-4C	30	30

Under certain conditions, some icing may occur on top of the balls. Periodically remove the ice with hot water or by tapping on the balls, physically removing any ice.

We recommend a Behlen Insulated Earth Tube be used. Where a waterer is replacing an electric waterer and the Poly Earth Tube is less than 12" deep and uninsulated, you may need to use heat cable in the riser pipe. A 250 watt submersible heater (52120088) is available for use when less than the minimum number of animals are using the waterer.

The drawings in these instructions provide slab dimensions and approximate anchor locations for various models. It is advisable to check the waterer for exact dimensions for anchor locations. This is because some variance due to the molding process is normal and the dimensions on the waterer may vary slightly from the drawing. Anchor bolts (not provided) may be set in concrete or anchors may be drilled in after the fountain is set in place. Use anchors for 5/16" bolts. **NOTE:** The slab should be at least 4" larger than the waterer on all sides.

Behlen[®]
COUNTRY

CUSTOMER SERVICE CENTER

PO Box 569
Columbus, NE
68602-0569

Ph: 800-447-2751
Fax: (402) 563-7447
www.behlencountry.com

Poly Earth Tube Installation Instructions

Your insulated Poly Earth Tube is designed to utilize the earth's heat from below the frost line, and keep the frost from penetrating through the tube and freezing the water pipe.

After you have all necessary components for this installation, dig a trench below the frost line from the water source to where the waterer will set.

Dig out about a 16" diameter hole beneath the waterer for the 12" diameter Poly Earth Tube.

Refer to the diagrams on the next pages for water pipe connection. **NOTE:** Install Shut-off Valve at an easily accessible location.

If you have clay soil or a soil that does not drain well, you will need to place about a foot of coarse gravel for pipe drainage at the bottom of the hole.

Connect several Poly Earth Tubes together to achieve your desired depth. Follow the installation instructions on the label of the Poly Earth Tube.

The Poly Earth Tube needs to be kept flush with the top of your cement slab. Set the outside frame of cement form and place a straight board or pipe across the center of the hole. (see Figure 1 below).

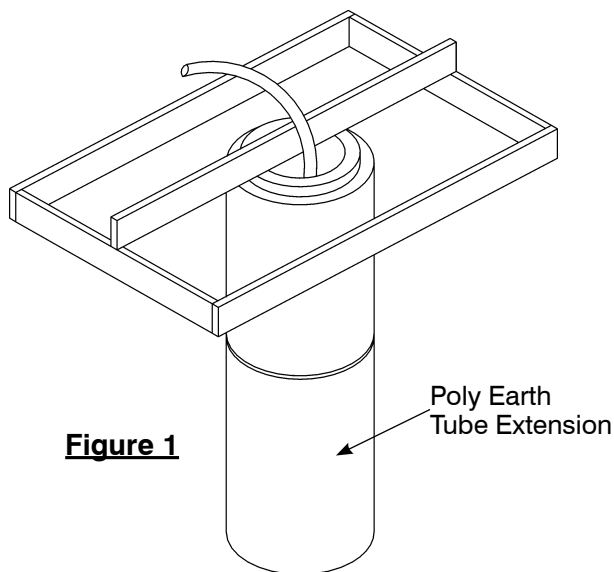

Figure 1

Attach the Earth Tube to board by using long screws or by plugging wire into the sides of the tube and tying the tube to the board.

Back fill around the outside of the Poly Earth Tube lightly at first, making sure the tube stays level at the top. Continue to fill and tap lightly until hole around the pipe is completely full. Avoid large clods or rocks in this fill area. Pour the cement level with the top of the Poly Earth Tube.

Waterer Installation Instructions

Remove valve cover and remove float valve assembly. Disconnect the hose assembly from the valve if the hose is attached. (In some models, the hose is separate from the valve assembly.)

Remove the lid(s) and float balls from the waterer. Locate the hardware package, it is generally attached to the rim of the waterer body.

Attach the four Tie Down Brackets with the four 5/16" x 1 1/2" lag screws. Use the small hole for mounting to the waterer, the large hole will be used for mounting to the concrete pad. **DO NOT OVER TIGHTEN LAG SCREWS.** Just snug the bracket up to the body.

NOTE: These Tie Down Brackets are not required on the SF-4C and the SF-2C which has molded-in mounting pads.

Turn the waterer upside down and place caulking around the outer bottom edge. Make sure the caulking is heavy enough to seal any irregularities between drinker and cement.

CAUTION: Any air leakage in this area could result in a frozen riser pipe.

Set in place with water line extended up through tunnel. Anchor to concrete. Slide insulating tube over water line and clamp with plastic tie. Connect valve to water line and clamp into position. **DO NOT OVER TIGHTEN BOLTS.**

Make sure all waterline connections are tight.

Turn on water and adjust valve for desired water level. **NOTE:** This is an easy-to-maintain valve with an operating range of 0 to 55 psi. It will work with pond or low pressure gravity feed systems. If increased flow is desired, a larger replacement orifice (54300968) is available. If a gravity feed system is used and more flow is desired, a low pressure, high-flow valve (54130338) is available.

On units with ball closures, the 10" balls are pre-weighted and foam filled to facilitate closing and make it easier for smaller animals to access the water. No further adjustment of ball weight should be necessary.

Replace float cover. **DO NOT OVER TIGHTEN THE TWO COVER BOLTS.**

When animals are first exposed to a ball unit, lower the water level approximately 1" to 2" so that the ball floats freely. This allows the animals to learn where the water is and how to drink from it.

**Typical setup
without Shut-off
Valve**

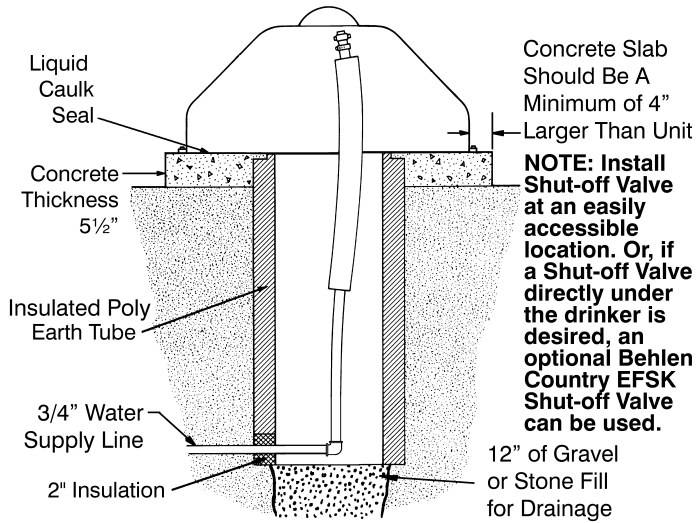

**Typical setup with
the EFSK Shut-off Kit
inside Earth Tube**

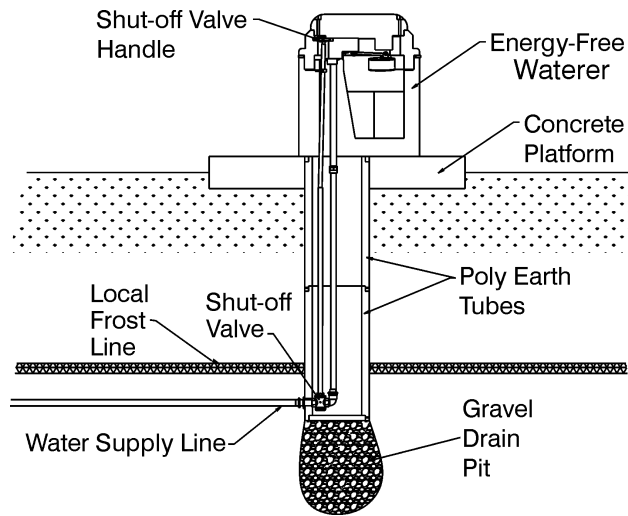

**Typical Remote
setup with the EFSK
Shut-off Kit**

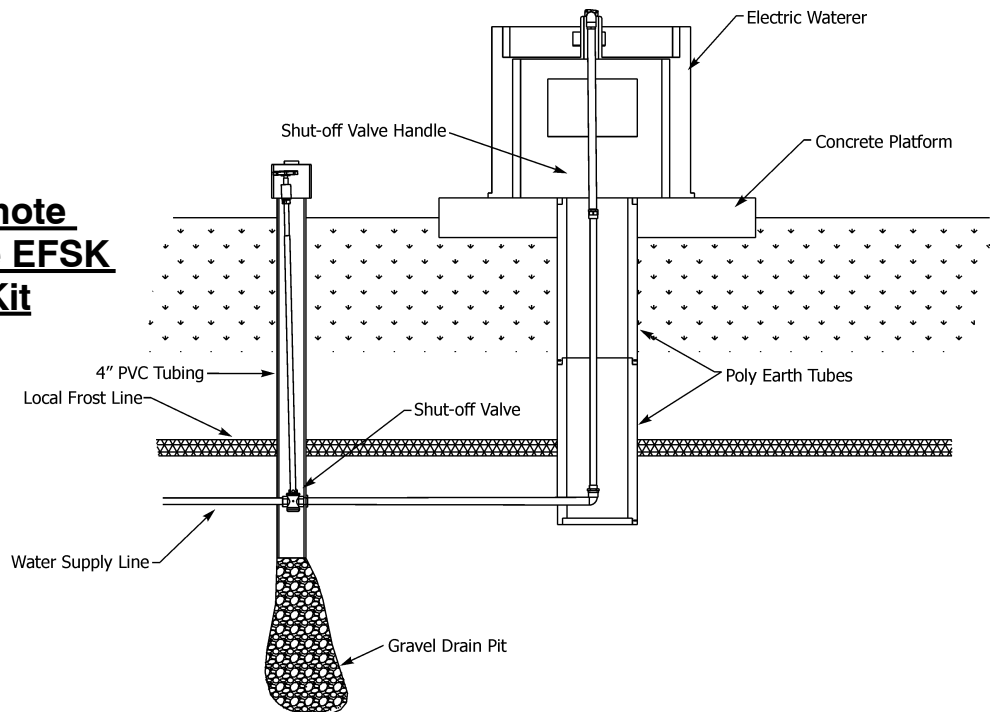

CONCRETE PAD SPECIFICATIONS

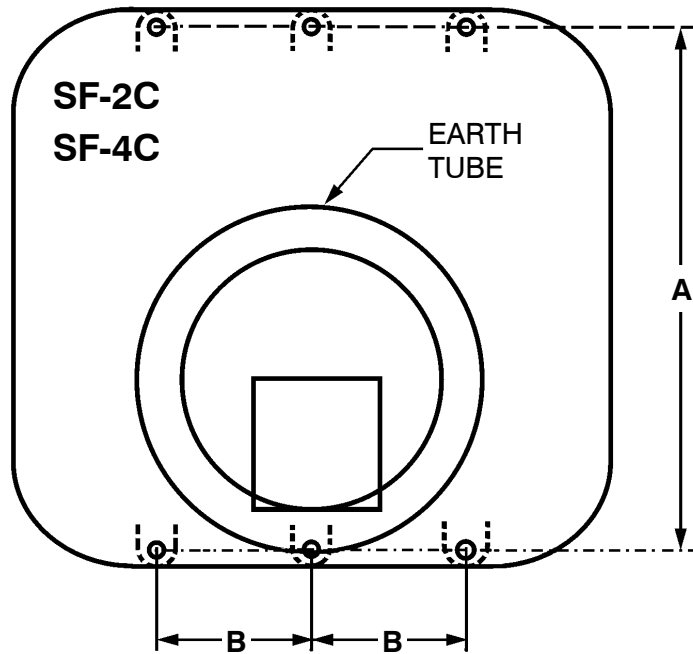
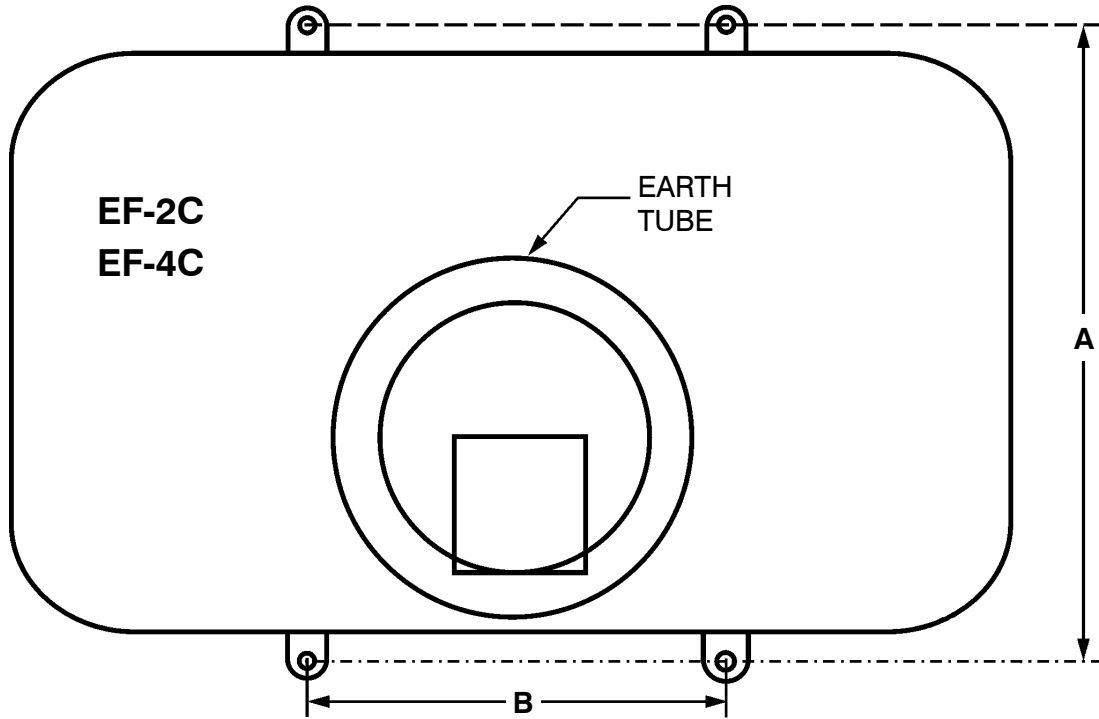

Model	A	B	Min. Slab. Size
EF-2C	21-3/4"	18"	28" x 44"
EF-4C	36-1/2"	18"	44" x 44"
SF-2C	27-1/4"	11"	30" x 48"
SF-4C	42-1/2"	11"	48" x 48"

Cleaning the MC Valve and Replacing the Plunger & Seal

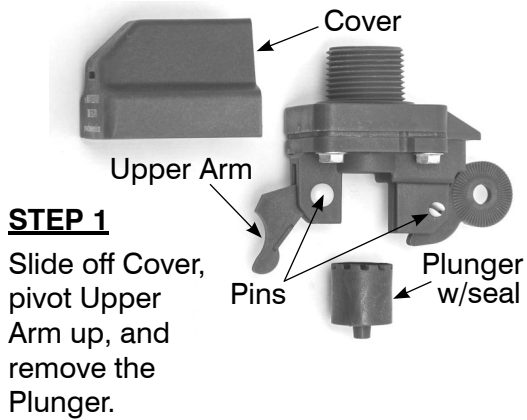

STEP 2
Clean the Rubber Seal in the Plunger and opening to the Valve of any mineral deposits or dirt buildup that may be obstructing the normal operation of the Valve.

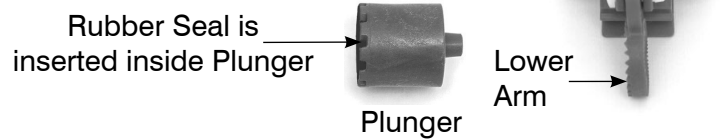

STEP 3
If the Rubber Seal is grooved but still pliable (not hard and brittle), you may flip it over and use the backside of the seal. If both sides of the Seal are hard, replacement Seals are available. In some instances both the Plunger and the Seal may need to be replaced.

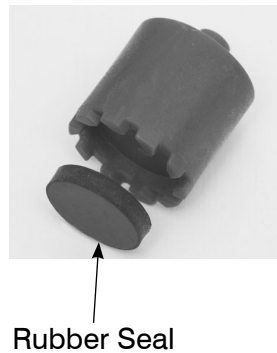

STEP 4
Replace the Plunger with the nipple facing out, and the rubber facing the valve. Pivot Upper Arm down over Plunger.

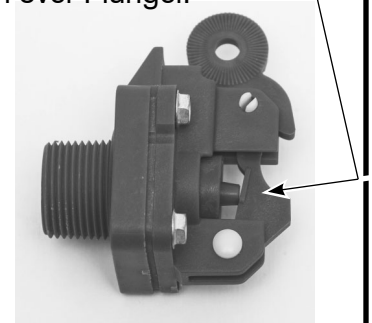

STEP 5
Replace the Cover to complete the cleaning of the Valve.

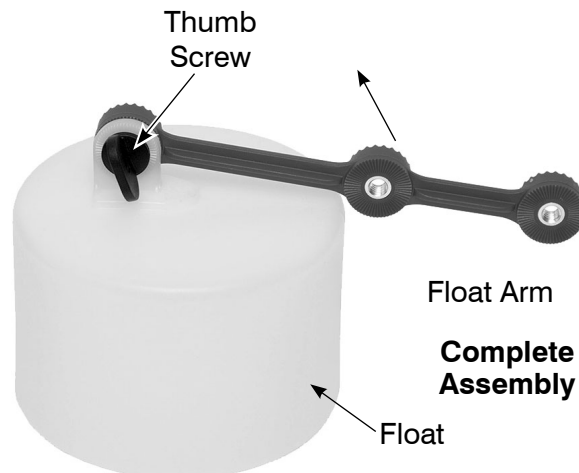

Instructions How To Assemble The Float And Arm To The MC Valve And How To Adjust The Valve

The MC Valve is already attached to the drinker. The float and arm assembly is with the hardware kit. They are packaged separately to prevent undue wear to the valve caused by the arm bouncing up and down during shipping.

The float and arm are attached to the valve by a thumb screw. The float can be positioned either closer or further away from the valve (see photo below left for the two float positions). Further away increases the shut off force of the valve. However depending upon which drinker is being used, the closer position may

be required to maintain proper clearance for the float to the side of the drinker. A clearance of at least 1/2" should be maintained to ensure smooth operation of the valve.

When attaching the float arm to the valve, be sure to attach the arm to the correct side of the valve. The grooves on the valve and float arm must match. Please note that the valve has coarse grooves on one side and fine grooves on the other. The fine grooved side is used with the float arm (see below for details).

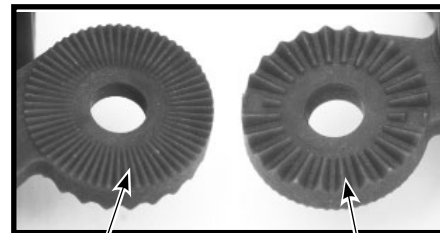

Fine

Coarse

To adjust the water level in the drinker, loosen the thumb screws and position the float and arm so that the valve is turned off when the water is at the desired level (see photo at left). It may take a couple of adjustments to get the correct level (1-1½" below the top of the trough). To speed the adjustment process, remove the drain plug and drain a little water out so that the valve turns on. Put the drain plug back and let water fill until the valve shuts off. If the level is not correct, repeat the process until the correct level is obtained and then replace the float cover. Your drinker is now ready for use.

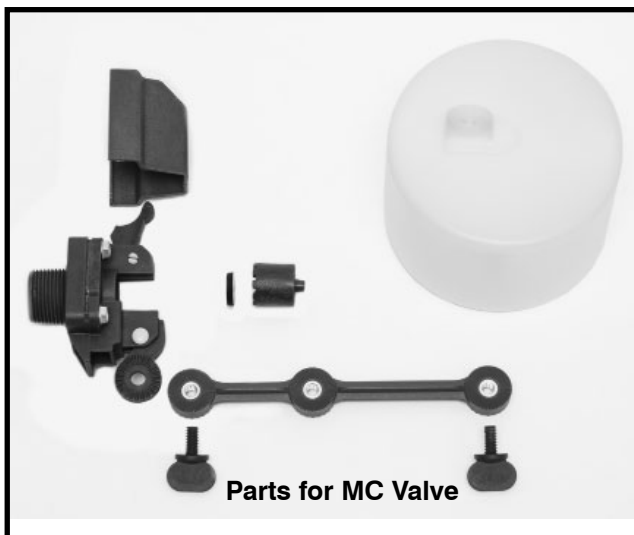

MC Valve Only
3888245S



Rubber Seals for MC
Valve 54300988
(Pkg. of 5)



Valve & Float Ass'y
3888244S



Float Ass'y
3888251S