

# Grader Blades

# Hardware Kit 80900210

## THANK YOU FOR PURCHASING THIS PRODUCT

Congratulations on your purchase. Behlen Country has been in the business of providing quality equipment to landowners for more than 80 years. Our 3-Point Equipment will provide many years of service when maintained by the operator and used in accordance with the capabilities of the product. For questions about this product, or for parts inquiries, please contact our Customer Service Center listed below.

### Fixed

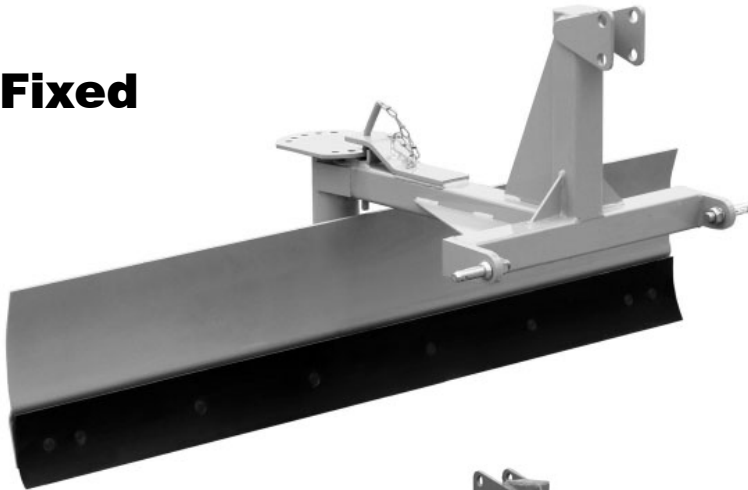

### Adjustable

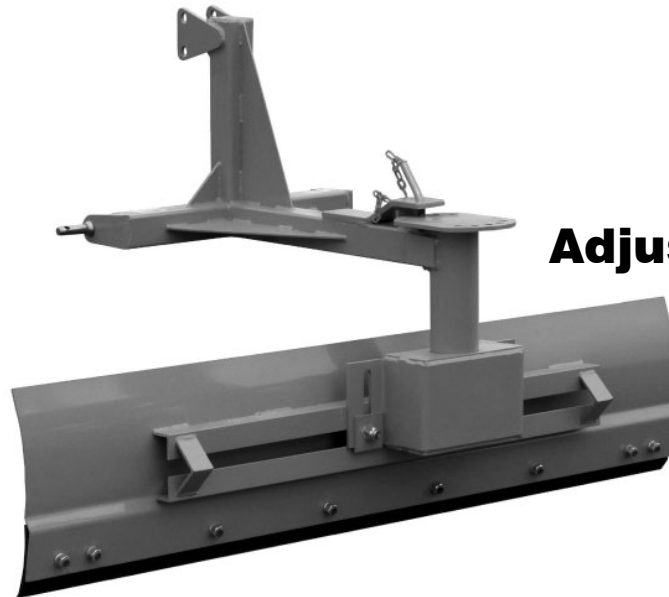

### STATEMENT OF POLICY

It is the policy of Behlen Country to improve its products where it is possible and practical to do so. Behlen Country reserves the right to make changes or improvements in design and construction at any time, without incurring the obligation to make these changes on previously manufactured units.

**Behlen**<sup>®</sup>  
**COUNTRY**

## CUSTOMER SERVICE CENTER

PO Box 569  
Columbus, NE 68602-0569

Ph: 800-447-2751  
Fax: (402) 563-7447  
[www.behlencountry.com](http://www.behlencountry.com)

## SAFETY

READ AND FOLLOW THE INSTRUCTIONS IN THIS MANUAL, ESPECIALLY IN THE SAFETY SECTION. FAILURE TO DO SO COULD RESULT IN SERIOUS INJURY OR DEATH.



THIS SYMBOL MEANS  
ATTENTION! BE ON THE ALERT!  
YOUR SAFETY IS INVOLVED!

TAKE NOTE! THIS SAFETY ALERT SYMBOL IS FOUND THROUGHOUT THIS MANUAL. THIS SYMBOL IS USED TO CALL YOUR ATTENTION TO INSTRUCTIONS CONCERNING YOUR PERSONAL SAFETY AND THE SAFETY OF OTHERS.

### CRITICAL TERMS:

The critical terms **CAUTION**, **WARNING**, and **DANGER** are used with the safety messages in this manual and with each safety decal. They are defined as follows:



### CAUTION



**CAUTION:** Indicates a potentially hazardous situation that, if not avoided, **CAN** result in minor or moderate injury. It also may be used to alert against unsafe practices.



### WARNING



**WARNING:** Indicates a potentially hazardous situation that, if not avoided, **MAY** result in serious injury or death, and includes hazards that are exposed when guards are removed. It may also be used to alert against unsafe practices.



### DANGER



**DANGER:** Indicates an immediate hazardous situation that, if not avoided, **WILL** result in serious injury or death. This Critical Term is to be limited to the most extreme situations, typically for machine components that, for functional purposes, cannot be guarded.

## Safety Precautions

Most accidents occur because of neglect or carelessness. Avoid needless accidents by following all of the safety precautions listed below.

- Machinery should be operated only by those who are responsible and are authorized to do so.
- Stop the engine, lower all equipment, lock the brakes, and remove the ignition key before dismounting tractor.
- Never stand between tractor and implement while tractor is being backed to a hitch. Loose fitting clothing should not be worn, to avoid catching on various parts.
- Detach implement in an area where children normally do not play.
- When performing adjustments or maintenance on an implement, lower it to the ground or block it securely at a workable height.
- Only a qualified operator should be permitted on the tractor when in operation; no riders allowed.
- Make certain everyone is in the clear before starting tractor or raising / lowering equipment.
- Operate the tractor and implement only while seated in the driver's seat.
- Reduce speed when transporting mounted implements to avoid bouncing and momentary loss of steering control.
- A heavy load can cause instability of the tractor. Use extreme caution during road travel. Slow down on turns and watch for bumps. Tractor may need front counter-weights to counter-balance the weight of the implement.
- Reduce speed on hillsides or curves to avoid possibility of tipping.
- Avoid driving too close to the edge of ditches or creeks.
- Do not transport implement on public roads without reflectors and slow moving vehicle emblem in daylight and with approved warning

lights at night and other periods of poor visibility.

- Due to the width of some implements, use extra caution on highways, farm roads, and when approaching gates.
- Always be sure the implement is in the proper position for transporting.
- Keep alert and watch the front, as well as the rear, when working with the implement.

## EQUIPMENT SAFETY GUIDELINES

- Safety of the operator and bystanders is one of the main concerns in designing and developing a Grader Blade. However, every year accidents occur which could have been avoided by a few moments of thought and a more careful approach to handling equipment. You, the operator, can avoid many accidents by observing the following precautions and insist those working with or for you adhere to them.
- Heed all safety decals and replace any that are not legible or missing. The locations of such safety decals are indicated in this manual.
- Never operate this equipment while using alcoholic beverages or drugs that can hinder alertness or coordination. Consult your doctor about operating this machine while taking prescription medications.
- Under no circumstances should children under the age of 18 be allowed to work with or around this equipment. Do not allow anyone to operate or assemble this equipment until they have read this manual and have developed a thorough understanding of the safety precautions and operation. Review safety instructions with all users often.
- This equipment is dangerous to anyone unfamiliar with its operation. The owner/operator is responsible for reading and following all of the instructions in the manual. The operator should be a responsible, properly qualified and physically able person familiar

with farm machinery and competent in this equipment's operation.

- Never exceed the limits of a piece of machinery. If its ability to do a job, in a safe manner, is in question - **DON'T TRY IT.**
- Use a tractor equipped with a Roll Over Protective System (ROPS) and seat belts. Only properly trained people should operate this machine. Always stop the PTO, set break, shut off the tractor engine, remove the tractor key, and allow implement to come to a complete stop before dismounting tractor. **Never leave equipment unattended with tractor running.**

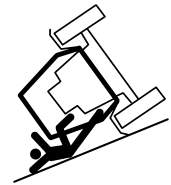

### BEFORE YOU START!!

Read the safety messages on the implement and as shown in the manual. Observe the rules of safety and common sense!

## Important Safety Information

Working with unfamiliar equipment can lead to careless injuries. Read this manual and the manual for your tractor before assembly or operating, to acquaint yourself with both machines. It is the Owner/Operator's responsibility, if this machine is used by any person other than yourself, or is loaned or rented, to make certain prior to operating:

1. The operator's manual is read and understood.
2. Safety issues are understood and followed, and proper usage is understood.

The use of this equipment is subject to certain hazards which cannot be protected against by mechanical means or product design. All operators of this equipment must read and understand this entire manual, paying particular attention to safety and operating instructions, prior to use. If there is something in this manual you do not understand, ask your dealer or manufacturer, to explain it to you. Improper use can occur on machines that are loaned out or rented to someone who has not read the owner's

manual and is not familiar with a Grader Blade.



**This Grader Blade** was designed for one-man operation from the tractor seat. Most accidents occur because of neglect or carelessness. It is the responsibility of the operator to see that no one is within twenty-five feet (25') of the blade when it is in operation. Do not operate the implement with another person near, or in contact with, any part of the Grader Blade. Serious personal injury or death may result if any attempt is made to assist operation by hand.



**Please remember** it is important that you read and heed the safety decals on the Grader Blade, and the safety rules set forth herein. Clean or replace all safety stickers if they cannot be clearly read and understood. They are there for your safety as well as the safety of others. The safe use of this implement is strictly up to you, the operator.



**All things with moving parts** are potentially hazardous. There is no substitute for a cautious, safety-minded operator who recognizes potential hazards and follows reasonable safety practices. The manufacturer has designed this implement to be used with all its safety equipment properly attached, to minimize the chance of accidents. Study this manual to make sure you have all the safety equipment attached.



**When maneuvering close to buildings** or passing through narrow areas, be sure to allow sufficient clearance for the implement and tractor. NEVER operate tractor and implement under trees with low hanging limbs. Operators can be knocked off tractor and run over by implement.



**This Grader Blade** is only designed for speeds less than 5 mph. Reduce speed on rough surfaces.



**When the use of hand tools is required** to perform any part of assembly, installation, adjustment, maintenance, repairing, removal or moving the blade, be sure the tools used are designed and recommended by the tool manufacturer for that specific task.



**Personal protection equipment** including hard hats, safety glasses, safety shoes, and gloves are recommended during assembly, installation, operation, adjustments, maintenance, repairing, removal, or moving the Grader Blade.



**Always use two people** to handle heavy, unwieldy components moving the Grader Blade.



**Never place any part of your body** where it would be in danger, if movement should occur during assembly, operation, maintenance, repairing, or moving the Grader Blade.



**Never place yourself** between the tractor and Grader Blade while implement is in operation. When removing, or adjusting equipment, be sure your body is never under the blade.



**A heavy load** can cause instability of the tractor. Use extreme care during travel. Slow down on turns and watch out for bumps. The tractor may need front counterweights to counter-balance the weight of the Grader Blade.



**Never use alcoholic beverages or drugs** which can hinder alertness or coordination while operating this equipment. Consult your doctor about operating this machine while taking prescription and some over-the-counter medications.



**DO NOT ALLOW RIDERS** on the Grader Blade or tractor at any time. There is NO safe place for any riders. NEVER ALLOW CHILDREN TO OPERATE OR BE AROUND BLADE.



**Before you operate the Grader Blade**, check over all pins, bolts and connections to be sure all are securely in place. Replace any damaged or worn parts immediately.



**Consult local utility companies** to make certain there are no buried gas lines, electrical cables, etc., in the work area before beginning operation.



**Do NOT allow anyone** who is not familiar with the safety rules and operation instructions to use this Grader Blade.



**Never replace any bolt** with any length other than what is specified in this manual. A longer, or protruding fastener is more likely to grab loose clothing or gloves which can result in serious injury or death.



**Watch for** hidden hazards on the terrain during operation.



**Turn curves** or go up or down hills only at a low speed and at a gradual steering angle. Make certain that at least 20% of the tractor's weight is on the front wheels to maintain safe steering. Slow down on rough or uneven surfaces, and loose gravel.



**Check that all hardware** is properly installed. Always tighten all bolts to proper torque. Make sure attachment is properly secured, adjusted and in good operating condition.



**Where replacement parts are necessary** for periodic maintenance and servicing, genuine factory replacement parts must be used to restore your equipment to original specifications. The manufacturer will not be responsible for the use of unapproved parts and/or accessories and the damages that can result in their use.



**Keep alert and watch** the front as well as the rear when working with equipment. **DO NOT** operate close to ditches or creeks. Be careful to avoid catching implement on stumps or other immovable objects.



**Make adjustments to implement** only when it is attached to a tractor and blocked up. Always keep all persons and children away from area when performing adjustments, service or maintenance. Worn edges can seriously affect the Grader Blade's operation. Check for wear before each use and replace as necessary.



**Know your controls** and how to stop your tractor, engine, and implement quickly in an emergency.



**Do not operate the Grader Blade** without checking that all movable parts are in good working order. Always use care when operating the Grader Blade.

# INSTRUCTIONS

## Tractor Requirements and Preparation

The Grader Blade is designed to fit Category 1 tractors equipped with a standard 3-Point hitch. Behlen Country carries sub-compact, standard, medium and heavy duty adjustable Grader Blades. Note: Some Category 0 tractors have very short lift arms or 5/8" diameter (Cat 0) lift arm ball ends. The Sub-compact Grader Blade will fit these tractors if equipped with the Cat 0 pull pins. The pins need to be installed on the inside of the 3-Point frame.

Check the tractor's 3-Point hydraulic lift system. It should operate up and down smoothly and have enough power to lift the Grader Blade. Refer to your tractor's operators manual or dealer for any adjustments necessary to put the 3-Point hydraulic lift system in good working order. (I & T shop manuals will list most specifications and adjustment instructions — available from most farm equipment dealers).



### CAUTION



**A heavy load can cause instability in driving a tractor. Make sure the front of the tractor is properly counterbalanced with weights. Tractor front end ballast may not always maintain tractor stability if tractor is operated on rough terrain at high speeds. In such cases, reduce speed and exercise caution - especially around turns. An unstable tractor could steer badly and possibly tip over, causing injury or death.**

## Mounting Instructions

1. Back tractor up to the Grader Blade making sure that the lift arms of tractor are on the outside of the lift points on the Grader Blade.
2. Slide lifting arms of tractor over lift pins on the Grader Blade.
3. Use lynch pins (customer supplied) to secure implement to the tractor.
4. Connect top link (customer supplied) from

the tractor to the top center lifting point of the Grader Blade and insert hitch pin (customer supplied).

5. Make any adjustments necessary to level the blade from side to side. On Adjustable models change the blade angle as desired.



**When using blade in reverse position, extra care should be taken not to ram into piles of dirt or debris. Tractor lift arms and the Grader Blade are not built to take high impact loads in this position. Ramming backwards can also dislodge operator from seat and/or tractor controls, resulting in serious injury or death.**

## Preparation Procedure

- Thoroughly read and understand your Operator's Manuals.
- Before beginning operation, contact your local Utility Company to make certain there are no gas lines, electrical cables, etc., in the work area.
- Check for ditches, stumps, holes, or other obstacles that could cause the tractor to roll.
- Be sure tractor tires and rims are in good condition. Inflate tires to proper air pressure.
- All persons should be at least twenty-five feet (25') away during operation. Clear the area of helpers, bystanders, and especially children.
- Do NOT allow anyone to stand between the hitch and blade.
- It is recommended that only tractors with wide front axles use the Grader Blade. Tricycle front wheel arrangements are inherently unstable and can cause rollover accidents.
- Make sure all safety stickers are installed and in good condition. Replace if damaged.
- Do NOT allow riders. There is no safe place for anyone to ride or sit on tractor or implement.
- Check that all equipment is properly installed and securely attached to the tractor.

## Operation

**If you have any questions regarding the proper operation of this Grader Blade, contact your dealer or the manufacturer.**

The Grader Blade is designed for a wide range of applications: casting, side ditching, leveling, terracing, bulldozing and snow removal. The blade may be angled to windrow debris to the side for removal. It is the responsibility of the operator to see that no one else is within twenty-five feet (25') of the tractor when it is started.

- Take tractor out of gear. Shift to "Park" (if applicable).
- Grader Blade should be level when operating.
- Adjust top link so implement is flat on level surface.
- Before operation, make sure all adjustments have been made to the blade for desired operation.
- Lower blade to ground and start moving forward. Your speed will be determined by the condition of the soil. You may need to use less or more angle depending on the job.
- Speed of the tractor should not exceed 5 mph.
- When you are turning, lift the unit from the ground.
- Pass diagonally through sharp dips and avoid sharp drops to prevent "hanging up" the tractor and blade.
- Watch for hidden hazards on the terrain during operation.



**DO NOT TAKE A DITCH AT 90° (straight on)! Always go in at an angle or damage may occur.**



**Before dismounting power unit or performing any adjustments to the Grader Blade, lower 3-Point hitch and all raised components to the ground, operate valve levers to release any hydraulic pressure, set parking break, stop engine, remove key and allow implement to come to a complete stop before**

dismounting tractor. Never leave equipment unattended with tractor running.

It is essential that everyone involved in the operation, transportation, maintenance, and storage of this equipment be aware, concerned, prudent and properly trained in safety.



The moldboard blade is sharp. Exercise extreme caution when working around or near the blade. Failure to stay clear of the blade can result in serious injury.



Stop power unit and equipment IMMEDIATELY upon striking an obstruction. Turn off engine, remove key, inspect, and repair any damage before resuming operation. Never leave the seat of the tractor while engine is engaged.

## Adjustable Grader Blades

Adjustable Grader blades have tilt, angle and offset capabilities. To make adjustments, loosen bolts, make the necessary changes, and retighten all nuts securely. The lift arms on the tractor can be used for additional adjustments (see below).

## Fixed Grader Blades

### Casting

The blade should be angled horizontally - only enough to allow material to slide along it easily. The vertical angle (tilt) of the blade must be set to suit conditions. This is controlled by the lift arm leveling assembly (turnbuckle) on the tractor 3-Point hitch.

### Side Ditching

The horizontal angle should be at its sharpest. This is obtained by removing the shift pin and turning the moldboard so that the last hole in the circle plate is in line with the shift pin hole, then replace the shift pin. It is suggested that the blade be set in an offset position and then use the shorter blade side to be the cutting side.

This reduces the load movement on the end of the blade.

The vertical angle of the blade (tilt) is adjusted by means of the adjustment turnbuckles on the tractors 3-Point hitch. For the sharpest angle, lengthen the center link on the tractor as far as possible. Also, lower the adjustable leveling turnbuckle as far as possible.

### Leveling

The blade should be straight across, (i.e. 90°) to the line of travel of the tractor, in other words 0° horizontal angle. There should be a 0° vertical angle, the lift arms on the tractor's 3-Point hitch should be parallel to the ground.

The cutting pitch of the blade should be the opposite of that used in the side ditching and casting, with the cutting edge behind the top edge of the moldboard. This adjustment is made with the tractor center link.

### Terracing

Use a combination of ditching, casting, and leveling. The first cut is into the hillside in the ditching position. Continue until the terrace is at the proper depth, then switch to the casting position until the terrace width is established. It may be necessary to use the leveling position to complete the job.

### Bulldozing

When bulldozing, the blade is in the reverse position. Depending on the job, the casting, side ditching, 0° leveling position may be used. Snow removal can also be done with the blade in this position (blade in reverse cutting edge away from the tractor).



When using blade in a reverse position, use extra care - DO NOT RAM BLADE into dirt or snow piles! Tractor lift arms are not equipped to take high impact loads in this position.

### Grading

Grading is a combination of casting, side ditching, and leveling. Snow removal can also be done with the blade in this position.



Watch for hidden obstructions, like buried pipes, rocks, concrete piers or uneven slabs

of concrete when operating the Grader Blade as damage to the unit can occur. This is especially true with snow removal.

## Maintenance

Before servicing the Grader Blade, engage the parking break or place the transmission in "PARK", shut off tractor, and remove key.

1. Make certain any safety and instruction decals are attached to the Grader Blade 3-Point hitch. If they are lost, damaged, or painted over, order replacements from Behlen Country at 1-800-447-2751.
2. Telescoping parts must be kept clean and lubricated.
3. Clean unit of dirt and debris to minimize rusting and wear.
4. Keep all shields in place. Order new shields if damaged or missing.
5. Keep cutting edges sharp. Sharp cutting edges work easier and better. Check more often if working in rocky soil conditions. Blades are reversible. If blade edge becomes dull, unbolt it, reverse cutting edge and reattach securely.
6. Replace any worn or damaged parts immediately.
7. Check all bolts and nuts to make sure they are tight.
8. NEVER go underneath equipment. Never place any part of the body underneath equipment or between movable parts even when the engine is turned off. Servicing this Grader Blade does not require going underneath.

## Transportation Guidelines

Unit should be lifted as high as the tractor will allow being sure the unit is clear of the ground when transporting.

Care should be taken that at least 20% of tractor weight should be on the front tires.

A safe speed should be maintained during transportation.

Tractor weight ballast may be needed to even out weight to maintain proper steering.

Do NOT lower unit to pavement, blacktop or gravel road while transporting. Damage to the unit can occur.

When transporting on roadways always use a Safety Sign, and drive in a manner to allow other vehicles to pass you safely.



When traveling on public roads, whether at night or during the day, use accessory light and devices for adequate warning to operators of other vehicles. Comply with all federal, state, and local laws.

## Cleaning And Storage

### After Each Use

Remove large debris such as clumps of dirt, grass, crop residue, etc. from implement.

Inspect implement and replace worn or damaged parts

Replace any safety decals that are missing or not readable.

### Before Extended Storage

Follow cleaning instructions from above.

Wash implement using low-pressure water spray.

Be careful when spraying near scratched or torn safety decals or near edges of decals as water spray can peel decals off surface. Spraying near chipped or scratched paint can also cause paint to peel more.

Inspect implement for worn or damaged parts and replace any missing safety stickers.

Sand down scratches and edges where paint is missing and repaint to prevent rust.

Store the unit in a shed or under tarpaulin to protect from the weather. The blade should be resting on boards or some other object. Keep out of soil when storing.

Store in clean, dry place away from human activity or livestock.



# Trouble-shooting Guide

If you have any questions regarding the proper operation of this Grader Blade contact your dealer or the manufacturer

## **PROBLEM: BLADE WILL NOT PENETRATE SOIL**

### **Possible Solutions:**

- Cutting edge dull; replace cutting edge.
- Blade too straight; increase 3-Point hitch top link length.
- Soil too hard; loosen soil with scarifiers or disc. Wait for rain.

## **PROBLEM: MOLDBOARD DIGGING IN TOO MUCH**

### **Possible Solutions:**

- Blade pitch excessive; shorten top link.
- Ground too soft; wait for drier soil.

## **PROBLEM: 3-POINT FRAME BENT**

### **Possible Solutions:**

- Avoid hitting hidden objects in backfill position or ramming backwards at high speed into hard piles of soil. Use slow speed when soil conditions are unknown.
- Tractor may be too large, use smaller tractor. Always backfill at slow speed. Preferably use tractor of recommended horsepower. Slow down and use extra care.

## **PROBLEM: BENT MOLDBOARD**

### **Possible Solutions:**

- Small curve is normal from welding; can be removed but will not affect blade operation.
- Hitting hidden objects; Know soil conditions, use caution.
- Tractor may be too large, use smaller tractor or one that is heavy weighted and has four wheel drive. Preferably use tractor of recommended

horsepower. Slow down and use extra care.

## **PROBLEM: UNABLE TO HOLD LEVEL GRADE**

### **Possible Solutions:**

- Tractor draft control lifting blade. Set tractor draft control.
- Soil too hard, use scarifiers.

## **Grader Blade models available:**

- 80110710ORG - 5' Sub-Compact Grader Blade - angle & reverse
- 80110800YEL - 5' Medium Duty Grader Blade - angle & reverse
- 80110810YEL - 6' Medium Duty Grader Blade - angle & reverse
- 80110820YEL - 7' Medium Duty Grader Blade - angle & reverse
- 80110910YEL - 6' **Heavy Duty** Grader Blade - angle, offset, tilt & reverse
- 80110820YEL - 7' **Heavy Duty** Grader Blade - angle, offset, tilt & reverse

# **WARRANTY**

This unit carries a 1 year warranty, with the exception of wear parts. Dated proof of purchase required on all claims.

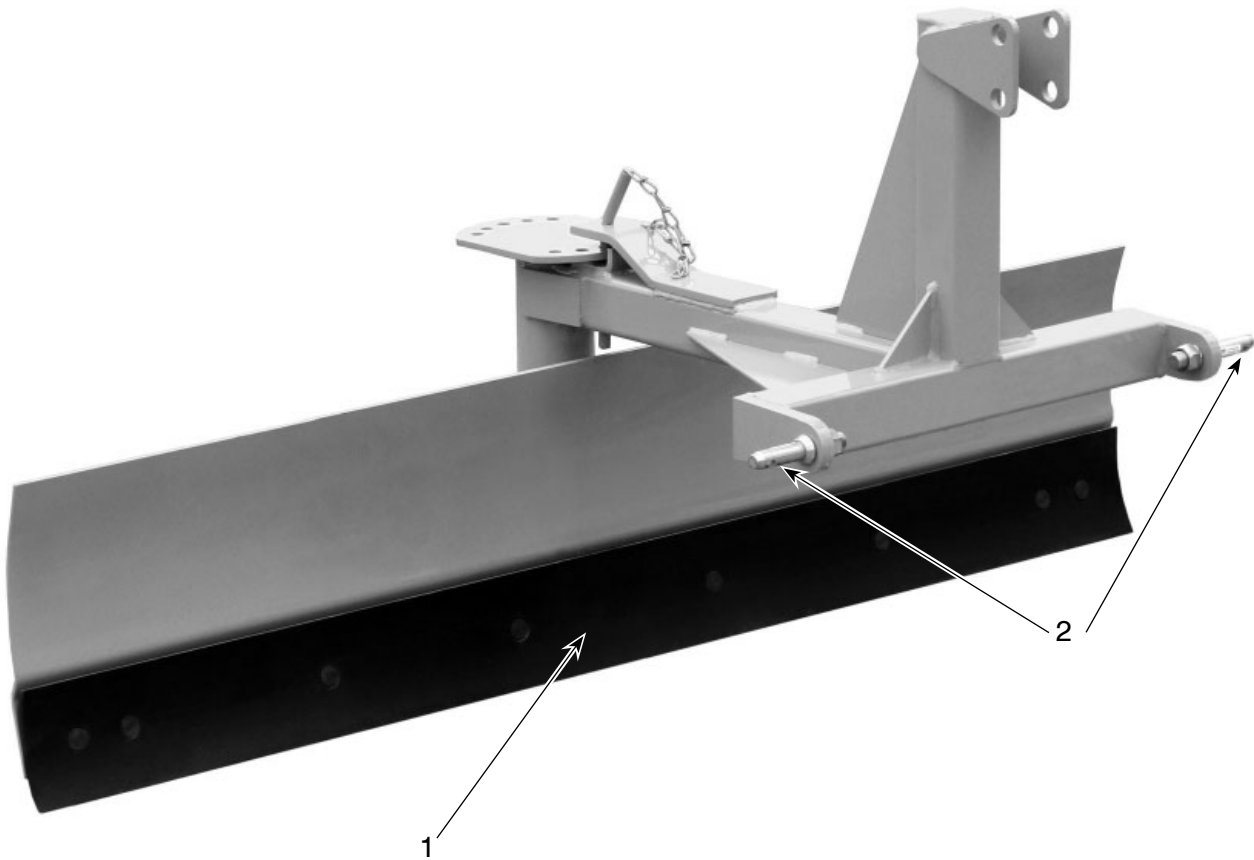

### Grader Blade Sub-Compact Parts List

No.	Description	Part No.	Qty
1	5' Cutting Edge	3018378	1
2	Category 1 Lift Pin	3018352	2

### Grader Blade Medium & Heavy Duty Parts List

No.	Description	Part No.	Qty
1	5' Cutting Edge	3018378	1
	6' Cutting Edge	3018379	1
	7' Cutting Edge	3018380	1
2	Category 1 Lift Pin	3018352	2