

Deluxe Horse Feeder (76130108)

Hardware Kit 22900108

THANK YOU FOR PURCHASING THIS PRODUCT

Behlen Country has been in the business of providing quality products for more than 80 years. Our products will provide many years of service when maintained by the owner and used in accordance with the capabilities of the product. For questions about this product, or for parts inquiries, please contact our Customer Service Center listed below.

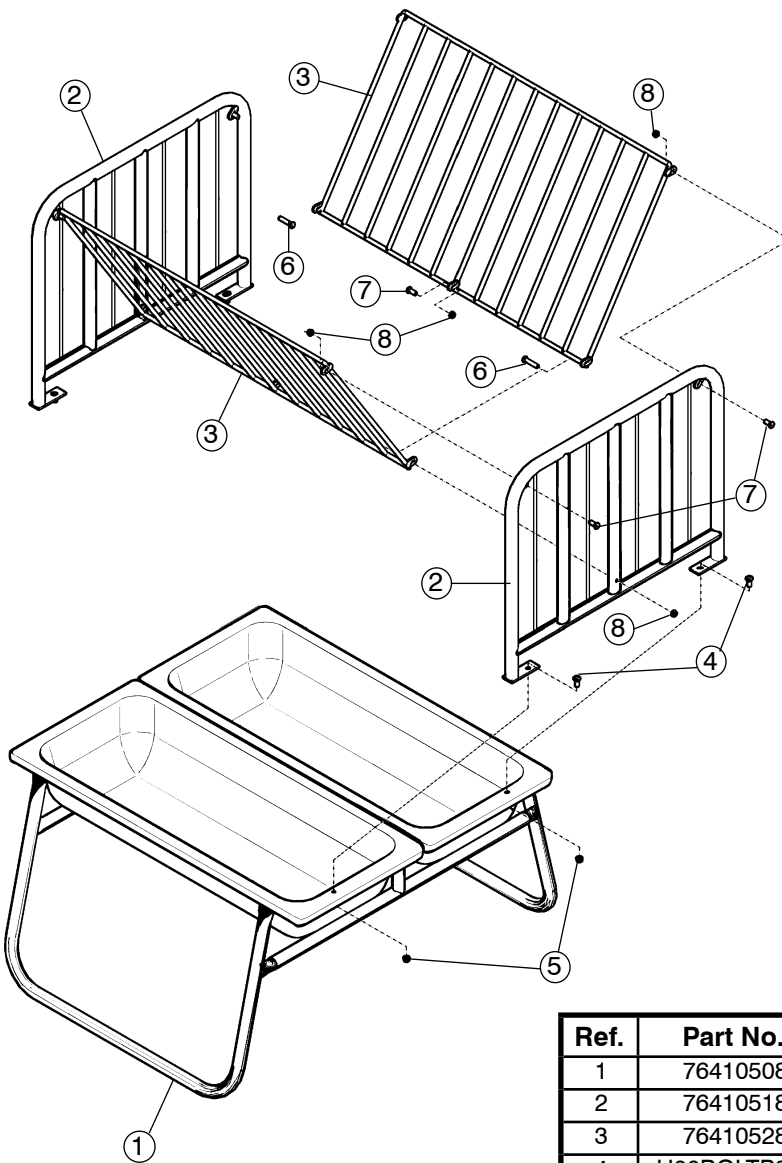

1. Flip the Bunk Weldment (1) over and drill four (one on each side of each bunk) 11/32" diameter holes in the poly liners using the holes in the angle end of the bunk as the drill guide.
2. Flip the Bunk Weldment (1) right side up. Attach the bottom of each End Weldment (2) to the bunk using the holes drilled in Step 1 with four H00BOLTP052 Bolts (4) and four 3/8" Flange Nuts (5).
3. Connect the Grill Weldments (3) to the top of the two End Weldments (2) with four 5/16" x 1" Bolts (7) and four 5/16" Flange Nuts (8) as shown.
4. Bringing the bottom of the Grill Weldments (3) together, loosely fasten it together at the middle of the bottom with one 5/16" x 1" Bolt (7) and one 5/16" Flange Nut (8).
5. Connect the Grill Weldments (3) to the bottom of the End Weldments (2) with two 5/16" x 2 1/2" Bolts (6) and two 5/16" Flange Nuts (8).
6. Tighten all bolts. **NOTE: Do not over tighten bolts through the tube of the End Weldment.**

Ref.	Part No.	Part Description	Qty.
1	76410508	5' Galv. Double Horse Bunk Weldment	1
2	76410518	5' Galv. Hay Rack End Weldment	2
3	76410528	5' Galv. Hay Rack Grill Weldment	2
4	H00BOLTP052	Bolt Carriage 3/8" x 1 1/4" Gr 5	4
5	2688220	Nut Flange Whiz-Lock 3/8" ZP	4
6	1328034	Bolt Carriage 5/16" x 2 1/2"	2
7	1328014	Bolt Carriage 5/16-18 x 1" ZP	5
8	2688216	Nut Flange 5/16-18 ZP	7

Behlen[®] COUNTRY

CUSTOMER SERVICE CENTER

PO Box 569
Columbus, NE
68602-0569

Ph: 800-447-2751
Fax: (402) 563-7447
www.behlencountry.com