

M1 Squeeze Chute with Split Tailgate

**Hardware Kit
62900238**

THANK YOU FOR PURCHASING THIS PRODUCT

Behlen Country has been in the business of providing quality products for more than 75 years. Our products will provide many years of service when maintained by the owner and used in accordance with the capabilities of the product. For questions about this product, or for parts inquiries, please contact our Customer Service Center listed below.

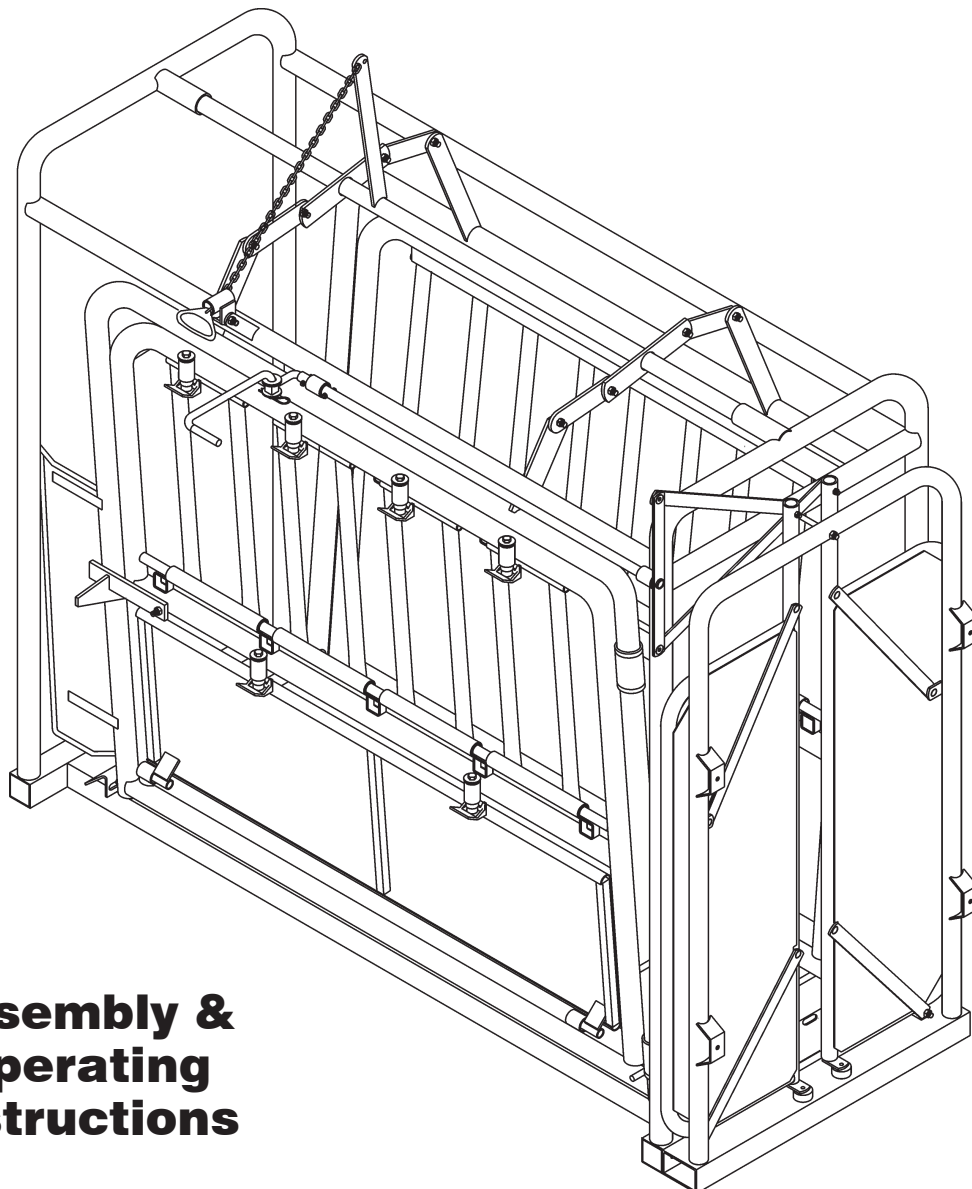

**Assembly &
Operating
Instructions**

**Behlen[®]
COUNTRY**

CUSTOMER SERVICE CENTER

PO Box 569
Columbus, NE
68602-0569

Ph: 800-447-2751
Fax: (402) 563-7447
www.behlencountry.com

ASSEMBLY OF THE SQUEEZE LATCH AND HANDLE

1.1 SQUEEZE LATCH ASSEMBLY

Determine what side of the squeeze chute you want to operate from.

Next, Install the squeeze latch into the bracket located on the top support tube on the side that you choose to operate from.

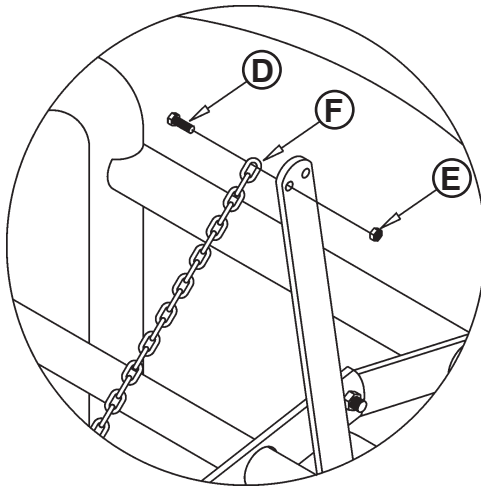
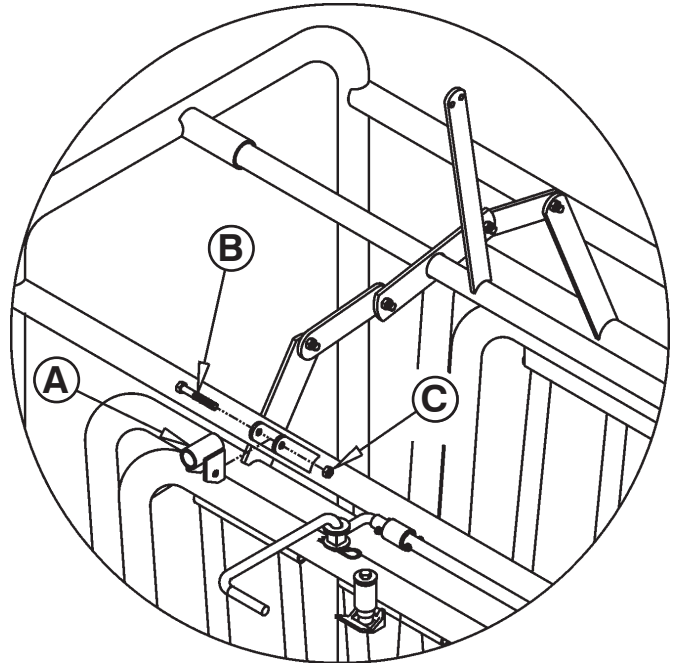

1.2 CHAIN ASSEMBLY

Attach the chain to the rocker arm lever located in the middle of the squeeze chute.

1.3 HANDLE ASSEMBLY

Feed the unattached end of the chain into the squeeze latch, then attach the handle with the hardware supplied.

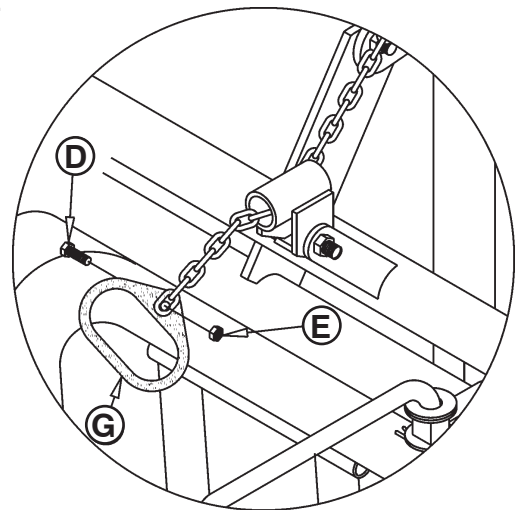

Squeeze Latch

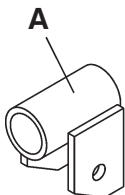

Bolt
1/2" x 3 1/2"

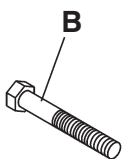

Bolt 3/8" x 1"



Nut, 1/2" Locking



Nut, 3/8" Locking

Chain 3/16" x 36" Long

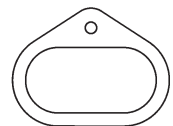
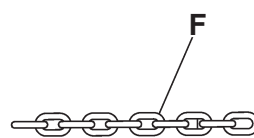

Handle

M1 SQUEEZE CHUTE ASSEMBLY & OPERATING INSTRUCTIONS

2.1 HEADGATE MOUNTING INSTRUCTIONS

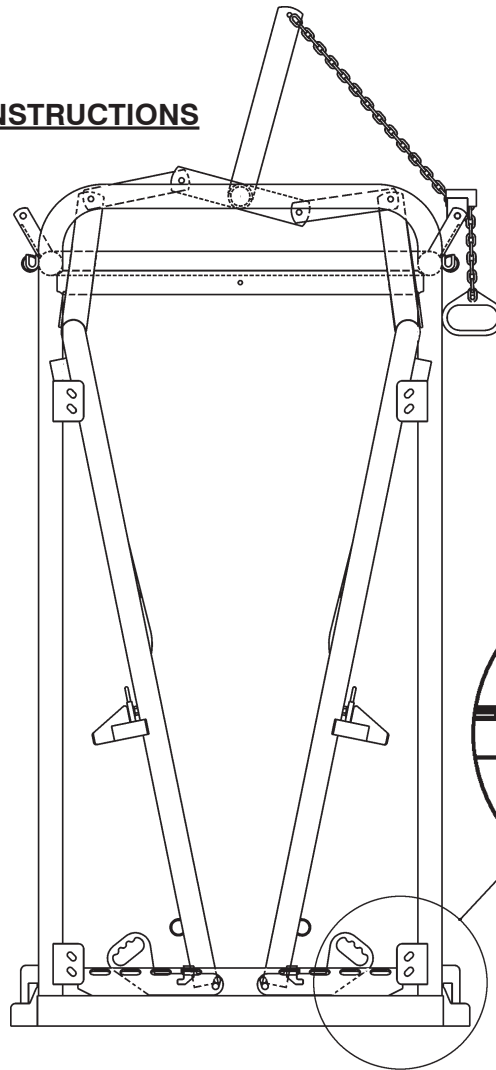

Use the top slot of each bracket to mount a self-catching headgate.

Use the bottom slot of each bracket to mount a manually operated headgate.

2.2 FLOOR ADJUSTMENT

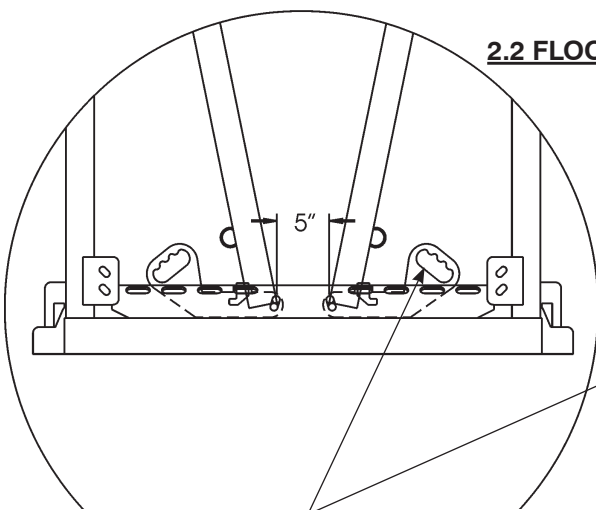

To adjust the bottom floor inward or outward, lift the floor handle out of the adjustment slots and move the floor to the desired setting.

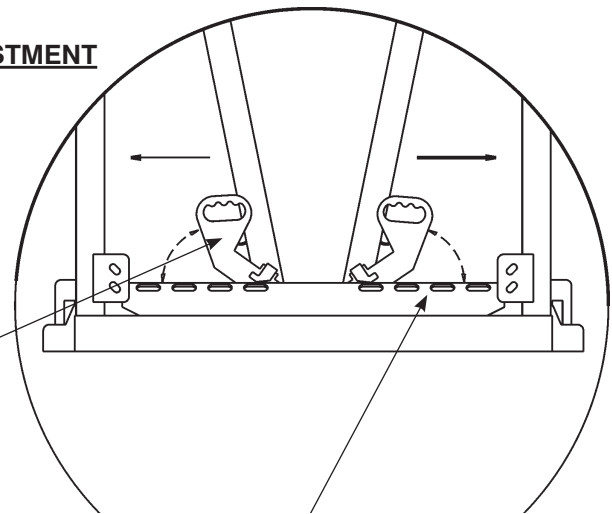

The slide track periodically needs to be cleaned and greased. This will help ease the adjustment of the side inward and outward.

M1 CHUTE ASSEMBLY & OPERATION

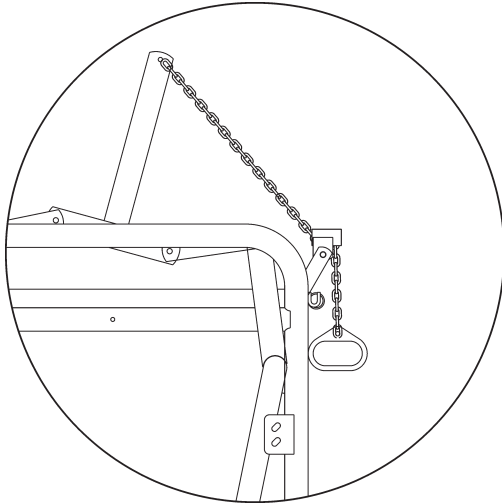

3.1 Squeeze Operation

To squeeze the animal in the chute, pull the handle and chain downward and latch the chain in the squeeze latch groove.

CAUTION! MAKE SURE THE CHAIN CATCHES SECURELY IN THE GROOVE OR THE SIDES MAY UNEXPECTEDLY FALL BACK INTO THE OPEN POSITION.

To release the squeeze, pull downward and out and the chain will slide out of the groove where it was latched.

Squeeze Return Spring: Attach spring to squeeze lever opposite the side of the squeeze chain and handle with two carabineers to assist in opening the chute when releasing the animal as shown in the illustration.

3428095 Spring Ext .105"x1.062"x12.5" 1 ea.
1488062 Carabineer connector 2 ea.

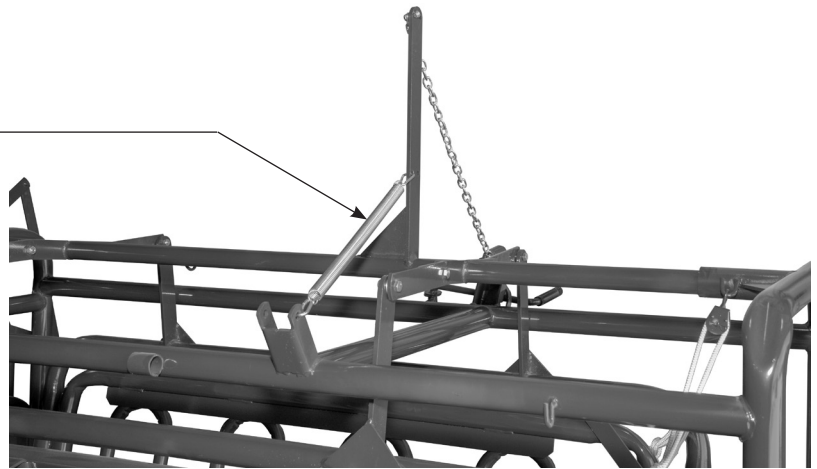

3.2 Left or Right Side Operation

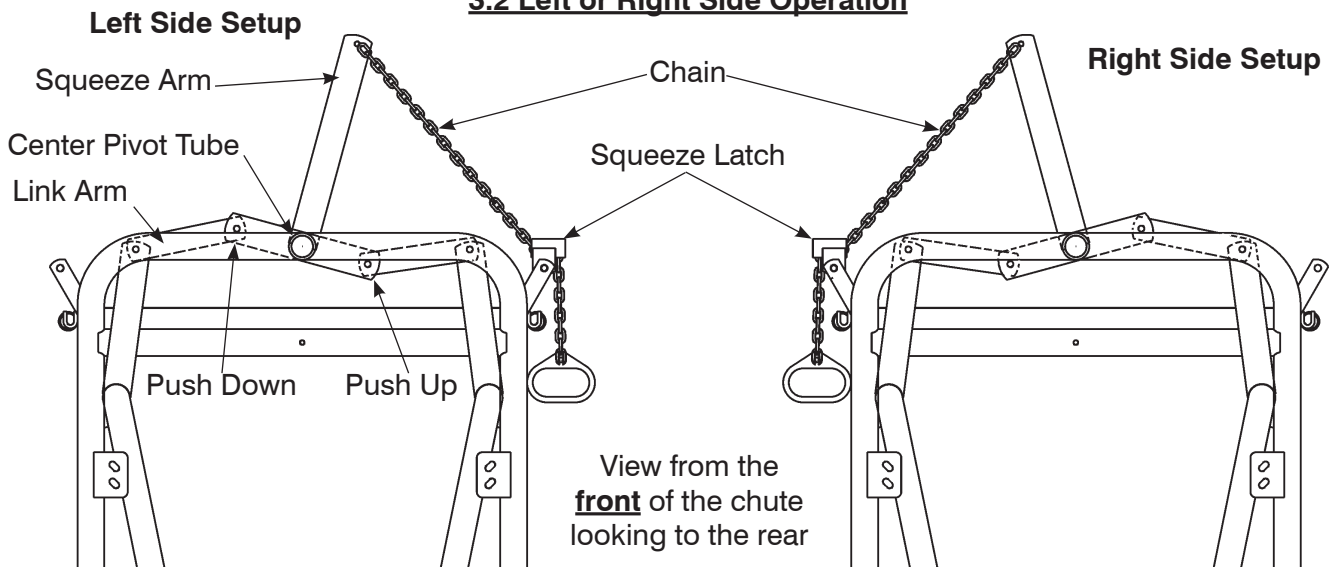

The M1 Chute has been set up from the factory as a left side operated chute. To make the chute a right-hand operated chute, do the following procedures:

1. Unbolt the chain from the squeeze arm.
2. Unbolt the squeeze latch and move it to the right side of the chute.

3. Rotate the center pivot tube to the right side. This pivot tube is designed to rotate to either side of the chute without unbolting the link arm (see diagram above).
4. Relocate the side door rope to the opposite side and reattach the squeeze latch and pull chain.

M1 CHUTE ASSEMBLY & OPERATION

4.1 Rope Routing Instructions

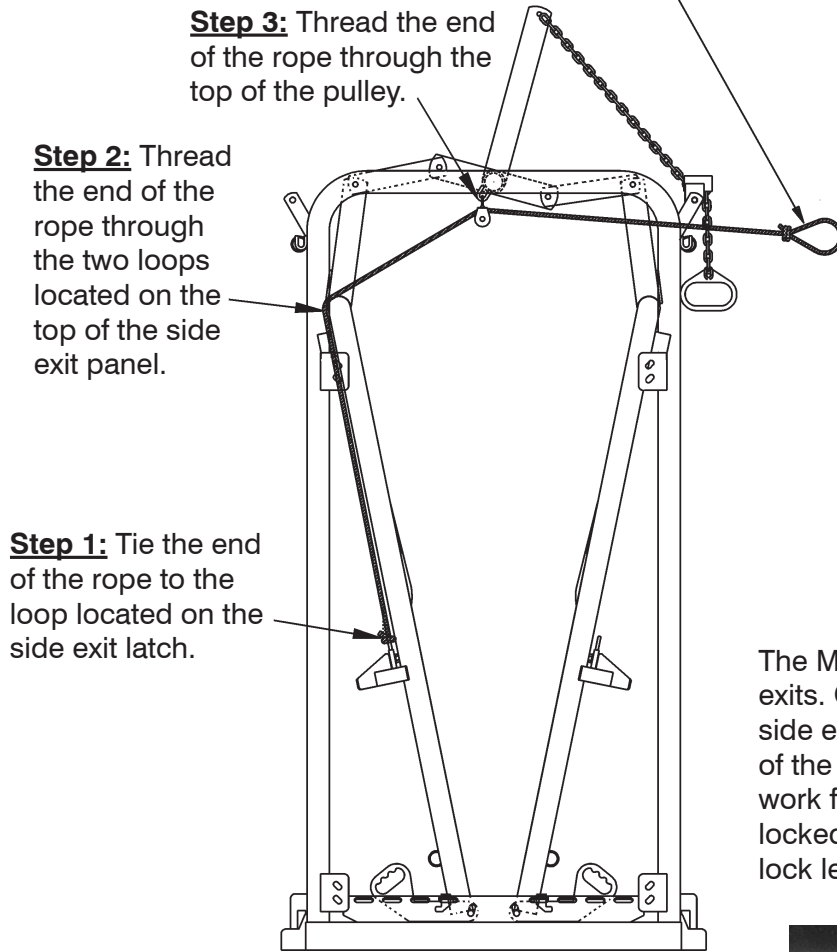

Step 4: Extend the end of the rope out and tie a loop in the rope which would fit the operator's hand. To keep the rope out of the way while operating the chute, wrap the rope around the cross tube.

4.2 Side Exit Operation

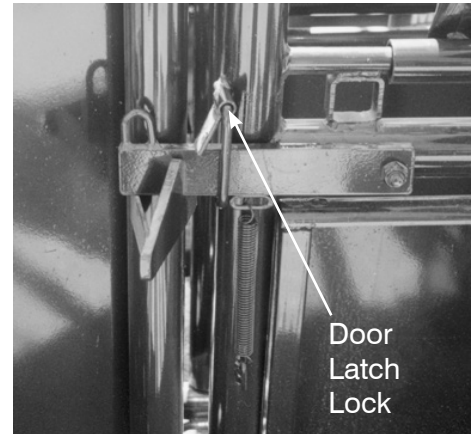

The M1 Chute was designed with dual side exits. Generally the operator will use the side exit door opposite the control side of the chute (i.e. the side the operator will work from). The side door latch can be locked down for transport by flipping the lock lever to lock against the latch.

4.3 Drop Latch Operation

To gain access to the inside of the chute while working cattle, lift the silencer latch and lower the drop door. For best performance, the latch should not hang down past the middle of the round tube.

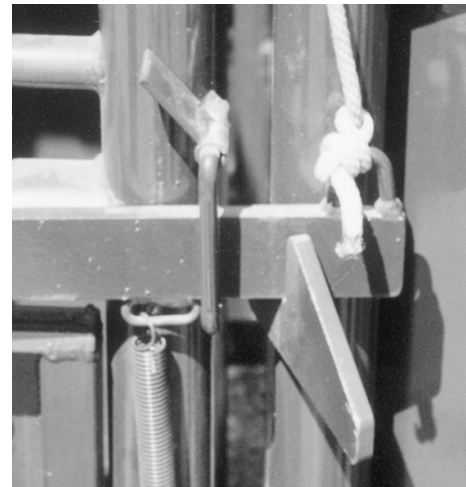
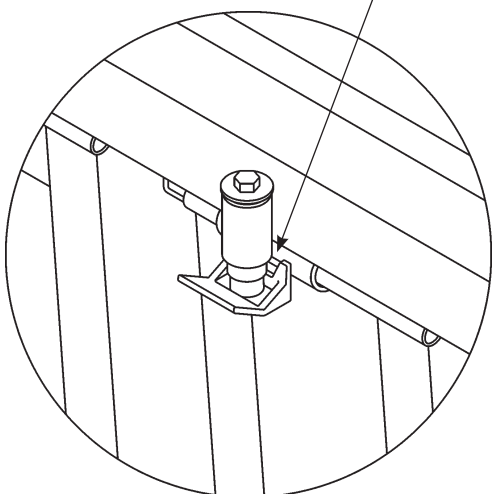

The side exit doors can be used for sorting animals or to help exit the animal from the chute if they can't exit from the front. Release the side squeeze pressure before opening the side exit door. Sometimes the pressure on the door may be so great that pulling on the rope will not lift the latch. Stand clear of the path of the door and the animal during this procedure.

M1 CHUTE ASSEMBLY & OPERATION

5.1 Trailer Hookup Instructions

1. Back the trailer manually into the slotted brackets located at the rear of the chute.
2. Hook the cable to the bracket located on the headgate base.
3. Turn the crank until the chute is flush against the bottom of the trailer.
4. Slide the 1" diameter pins into the brackets and insert the safety clips.

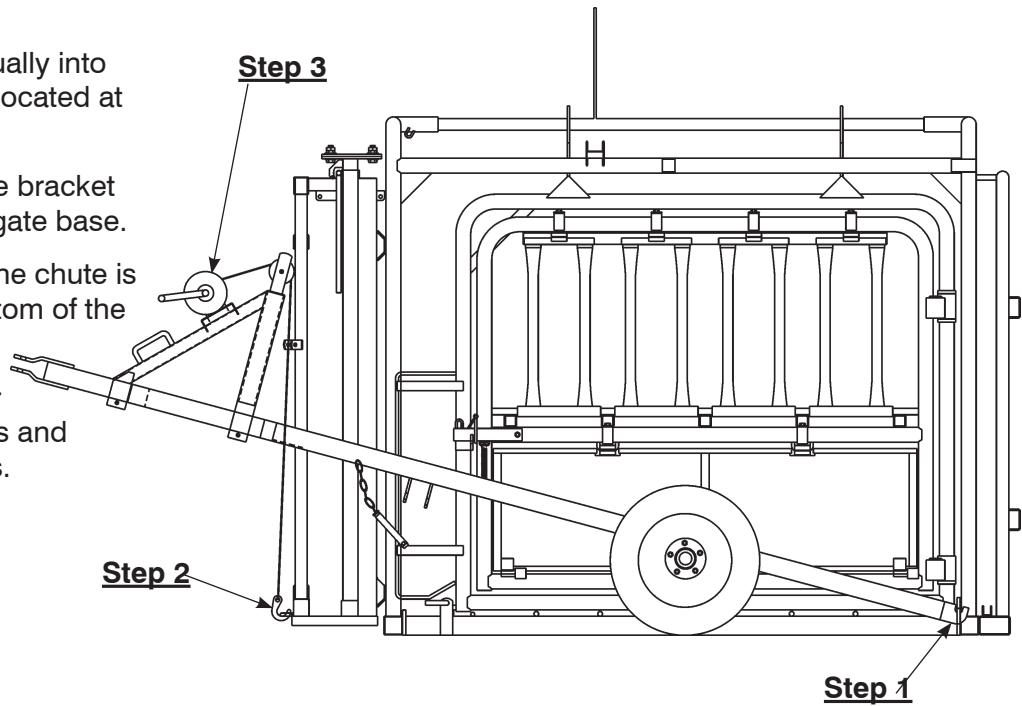

CAUTION: NEVER TRANSPORT THE CHUTE WITH TENSION ON THE CABLE.

After the chute is loaded, take the tension off the cable and winch.

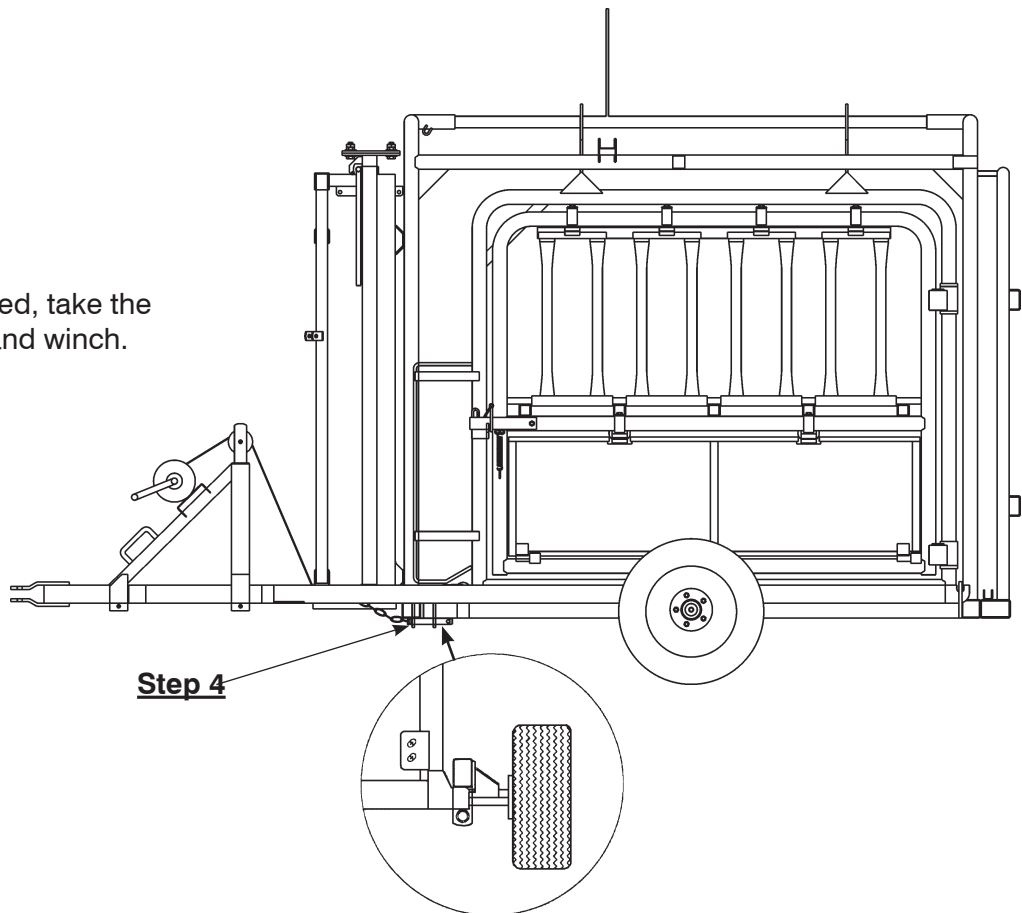

M1 CHUTE ASSEMBLY & OPERATION

6.1 Safety Points and Maintenance

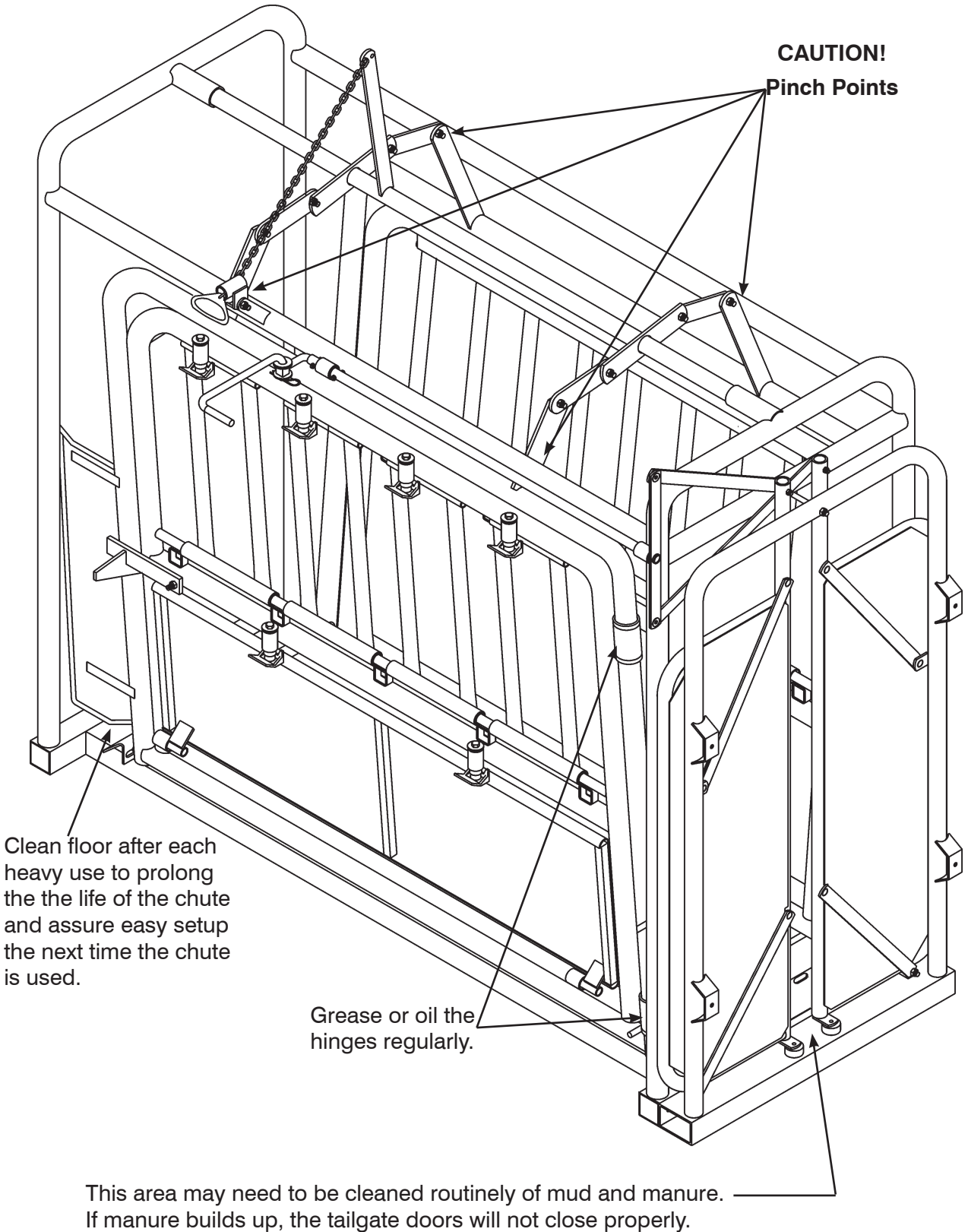

M1 CHUTE ASSEMBLY & OPERATION

7.1 Attaching a Behlen Country Palpation Cage

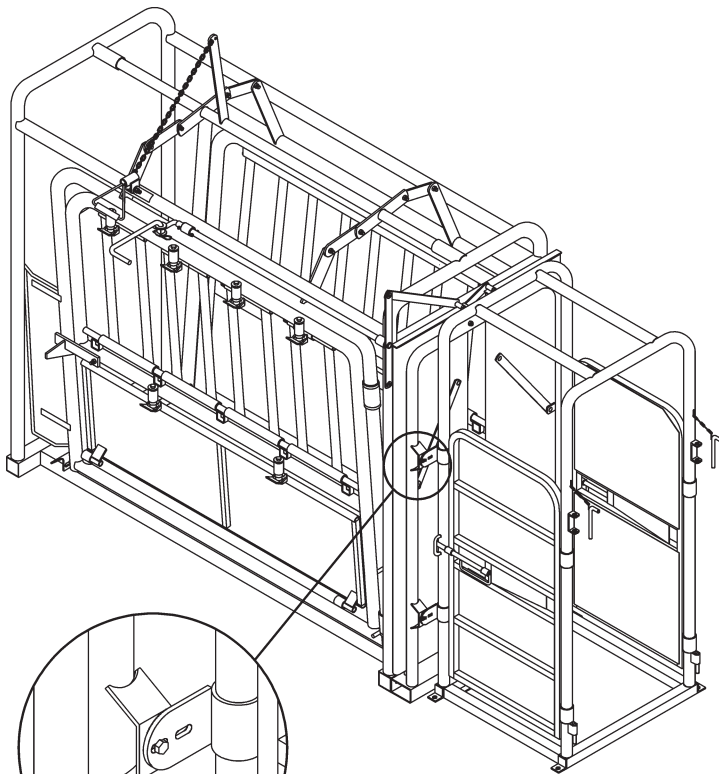
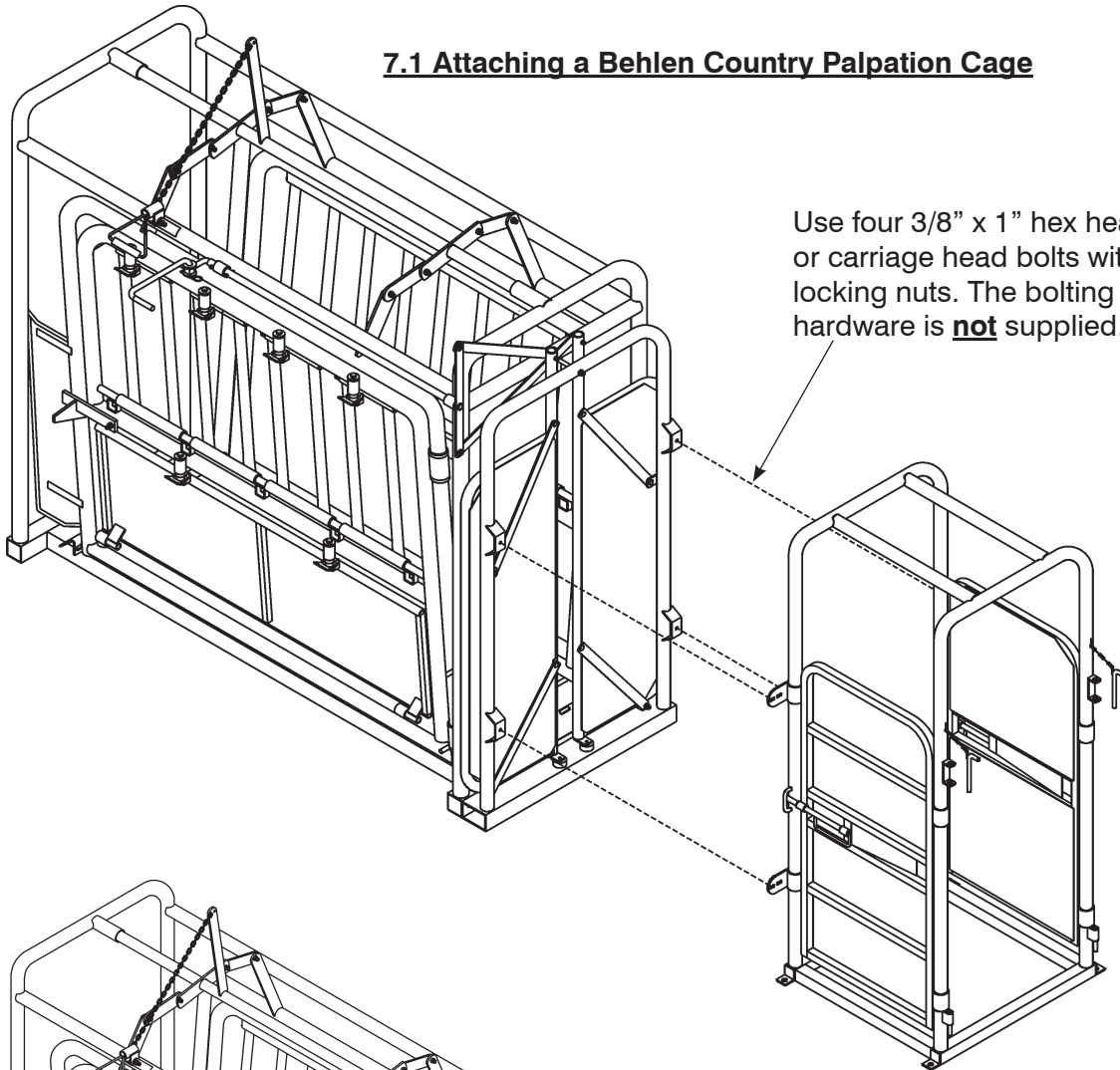

Bolt the palpation cage to the four brackets located on the back of the M1 tailgate arch. The brackets on the palpation cage have two slotted holes. Use the outer set of holes for hooking to the tailgate bracket.

M1 CHUTE ASSEMBLY & OPERATION

SPLIT TAILGATE

Step 1

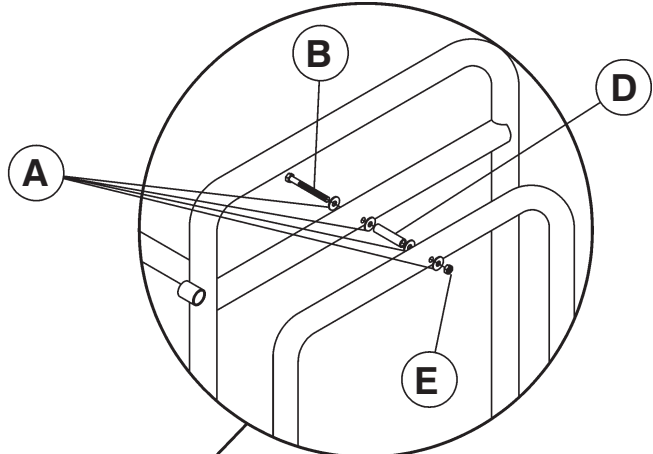
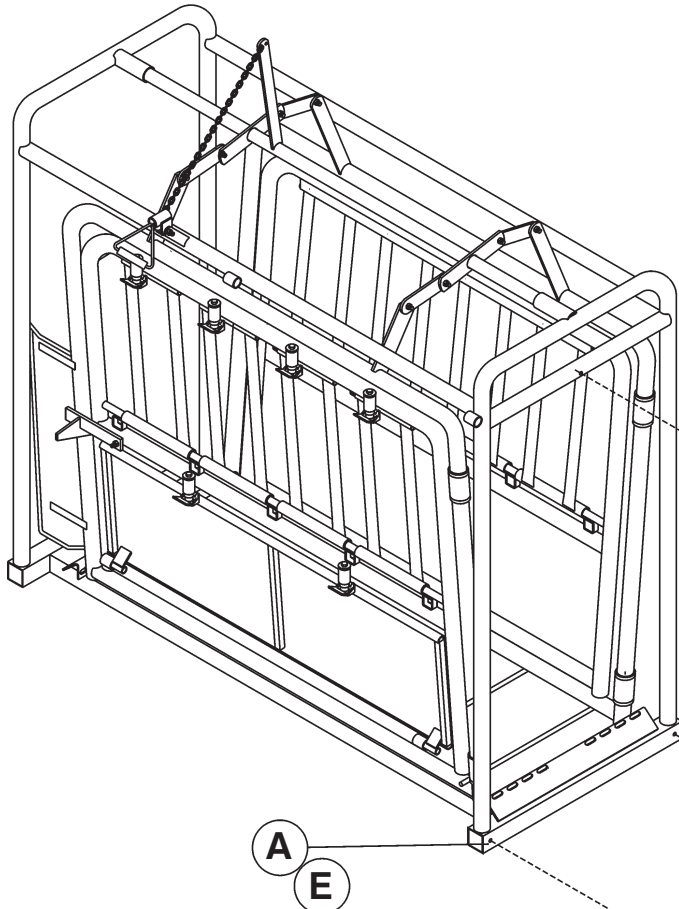

Bolt the top of the tailgate frame to the back of the M1 Squeeze Chute as shown. Leave finger tight until the bottom two bolts are attached.

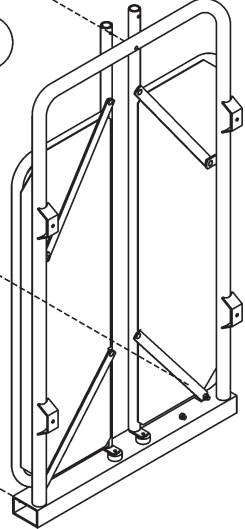

NOTE: This tailgate frame is correctly mounted if the four A.I. Cage brackets face outward as shown.

Bolt the bottom of the tailgate frame to the chute using the hardware indicated.



A

1/2" x 1" Hex Bolt

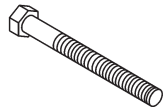

B

1/2" x 8" Hex Bolt



C

1/2" Washer

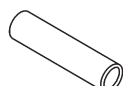

D

3 1/2" Pipe Spacer



E

1/2" Lock Nut

M1 CHUTE ASSEMBLY & OPERATION

SPLIT TAILGATE

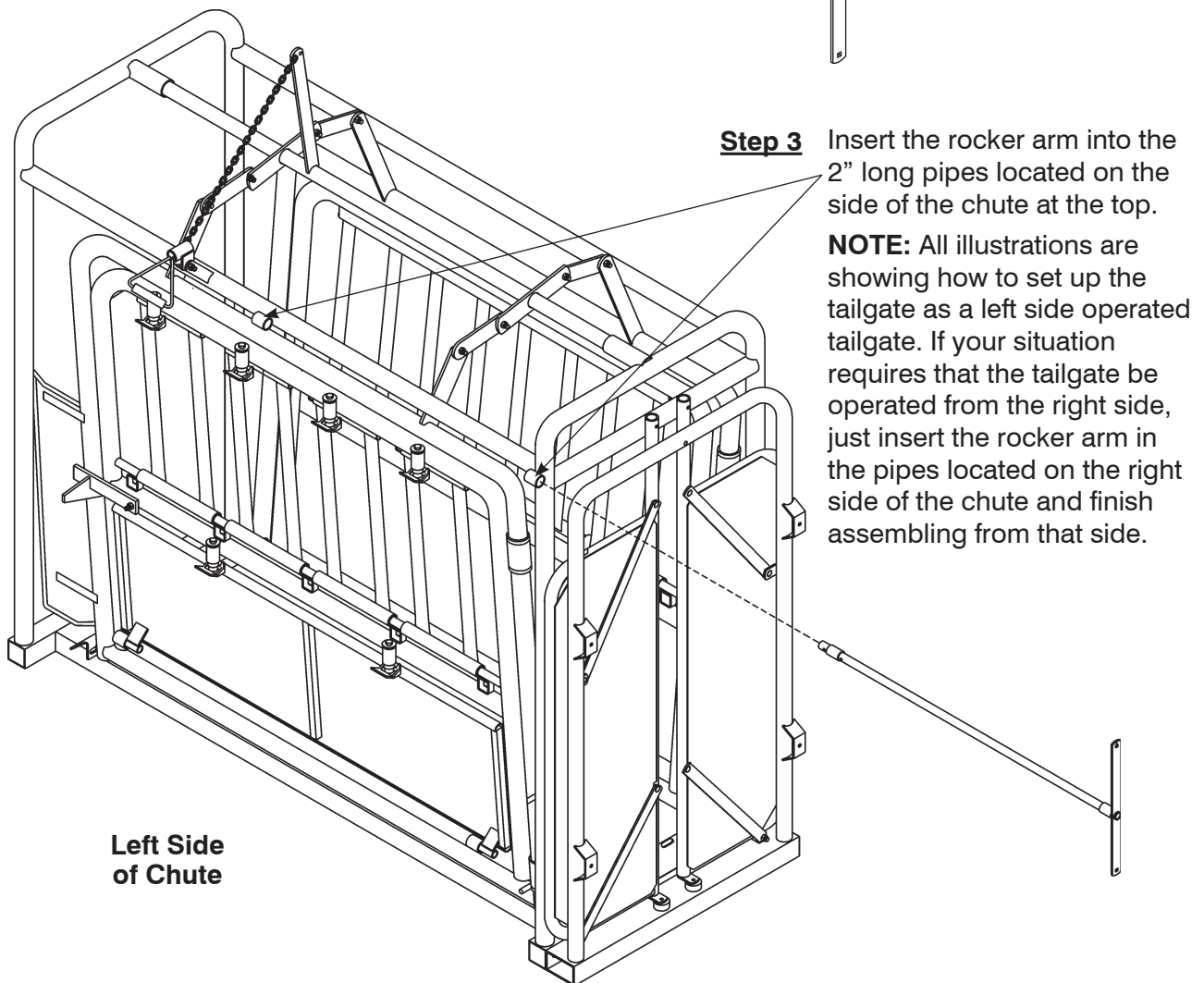
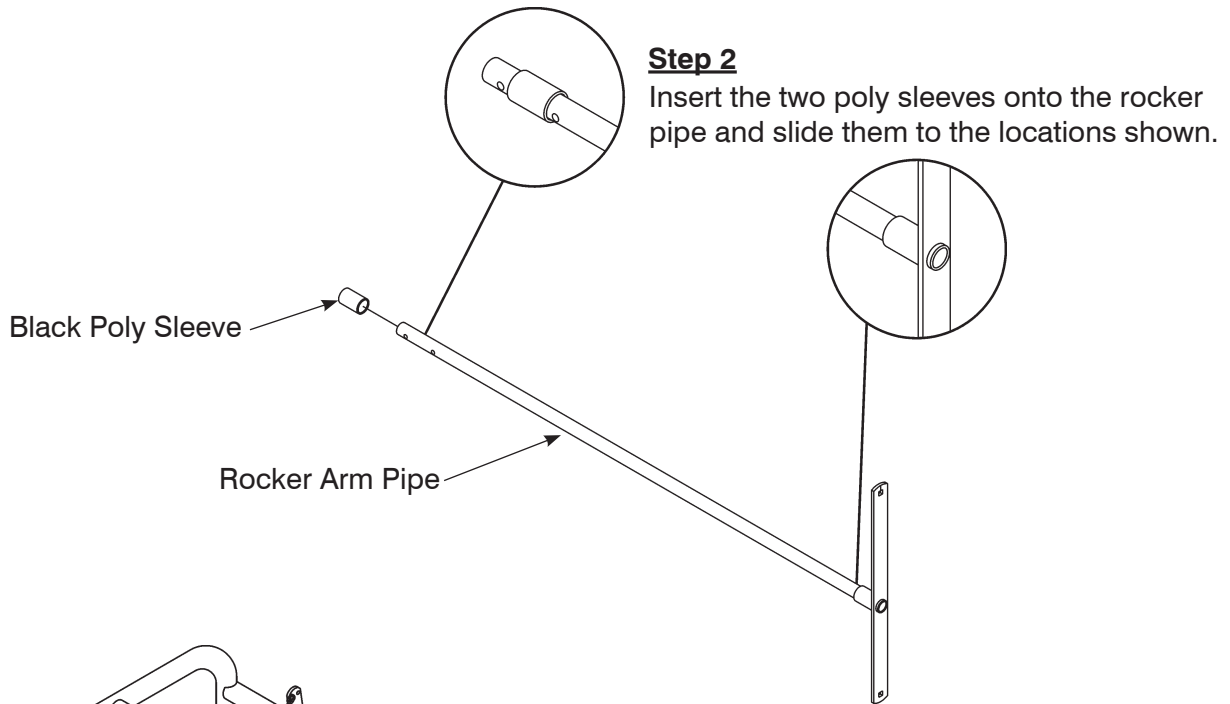

M1 CHUTE ASSEMBLY & OPERATION

SPLIT TAILGATE

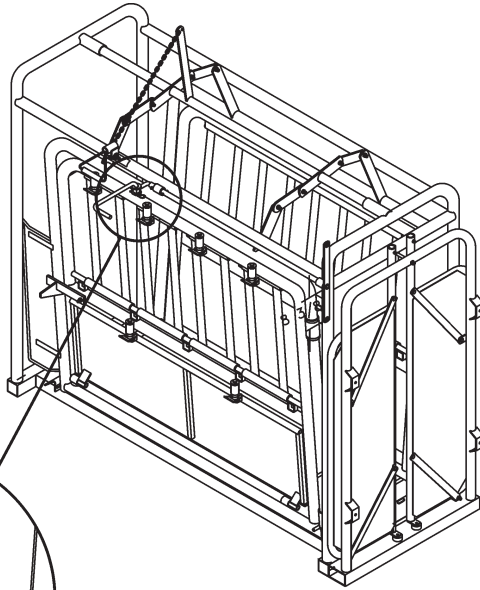

Step 4

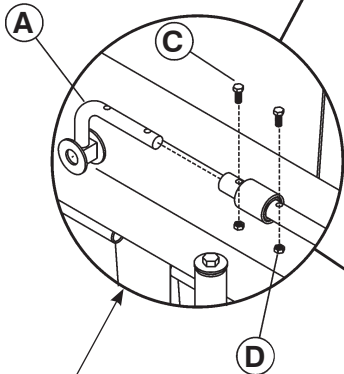

Slide the insert bracket into the end of the rocker arm and fasten the handle with the hardware shown.

Step 5

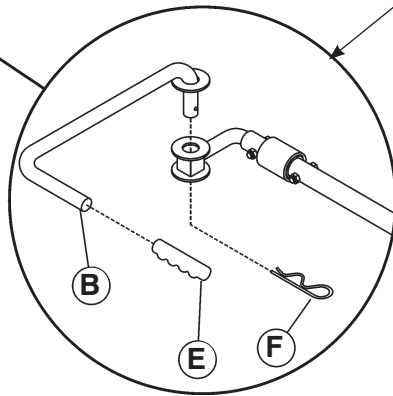

Attach the tailgate to the insert bracket and slide the safety clip into the small hole on the handle. Next, slide the hand grip onto the tailgate handle.

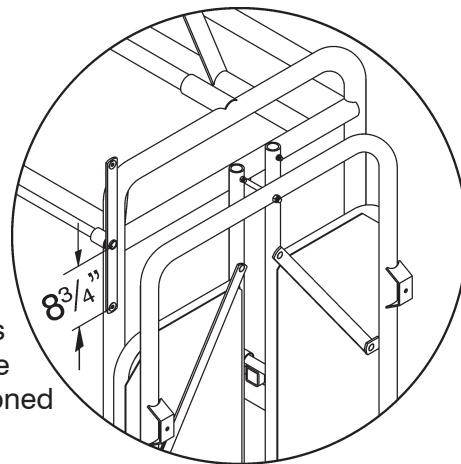

The tailgate rocker arm is assembled correctly if the short end (8³/₄") is positioned downward as shown.

Insert Bracket

A

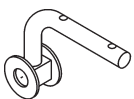

5/16" x 1 1/2" Hex Bolt

C



Safety Clip

F



Tailgate Handle

B

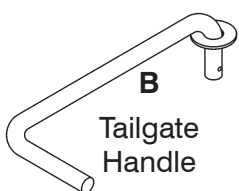

D

5/16" Lock Nut



E

Hand Grip

M1 CHUTE ASSEMBLY & OPERATION

SPLIT TAILGATE

Step 6 Attach the 20³/₄" long tailgate linkage to the top of the rocker arm. The other end of the linkage will attach to the left tailgate door.

Step 7
The 28" long tailgate linkage will attach to the right tailgate door and to the bottom of the rocker arm.

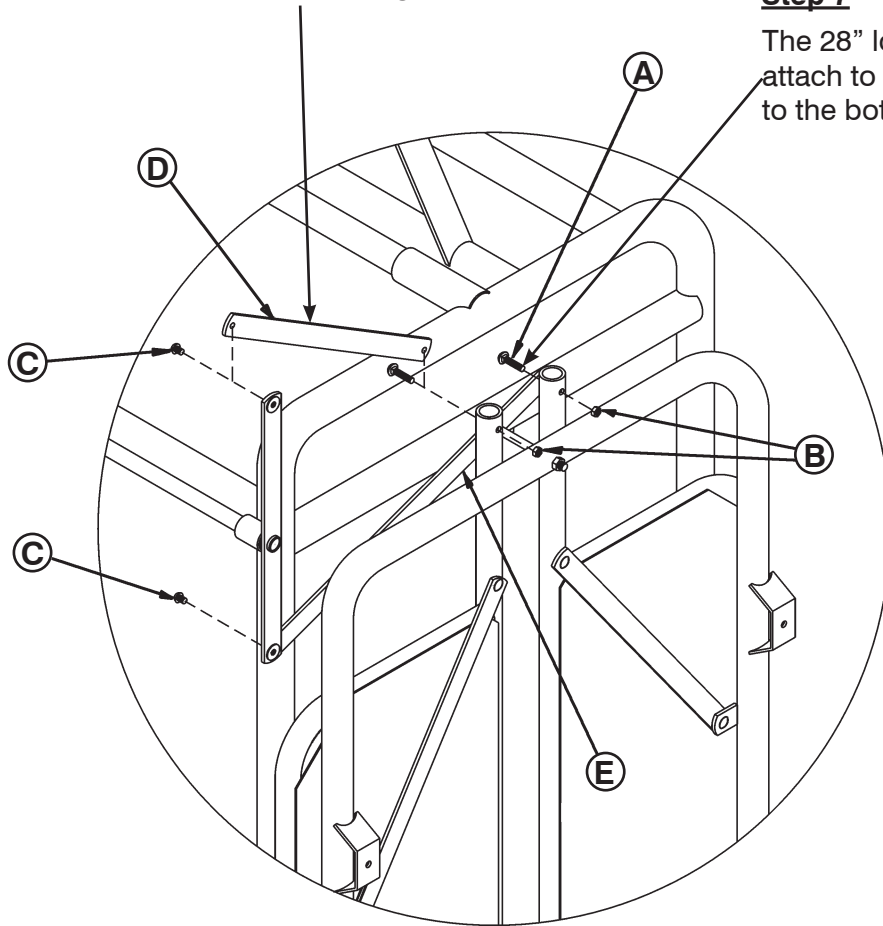

- A**
3/8" x 2 1/2"
Carriage Bolt
- B**
3/8"
Lock Nut
- C**
3/8" x 1/2"
Button Head Screw

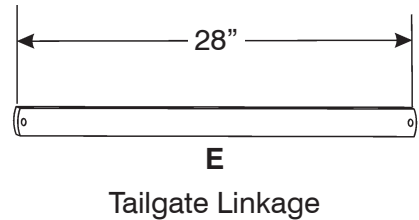
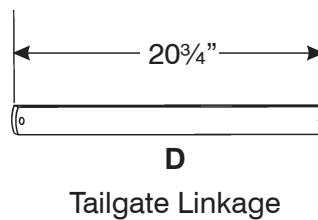

M1 CHUTE ASSEMBLY & OPERATION SPLIT TAILGATE

Pull down on the tailgate handle to raise the tailgate doors.

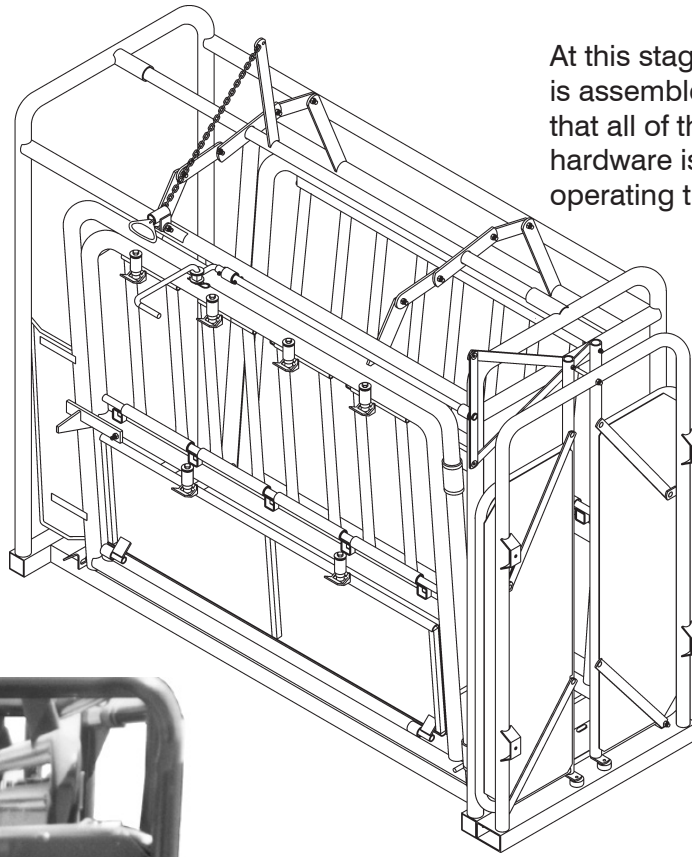

At this stage, the tailgate is assembled. Make sure that all of the bolting hardware is tight before operating the tailgate.



Periodically, clean the mud and manure from this area. Excessive buildup will prevent the doors from closing correctly.